

ITEM NO.	QTY.	PART NO.	MATERIAL	DESCRIPTION
1	1	J16-6 TANK	304 S/S	16 GALLON VESSEL ASSEMBLY
2	1	J16 INLET	304 S/S	3/4" MNPT INLET
3	1	J16 OUTLET	COPPER	3/4" MNPT OUTLET
4	1		BRONZE	3/4" FNPT FOR RELIEF VALVE
5	1	100XL .75 150LB	BRONZE	RELIEF VALVE SET AT 150PSI, 210°F
6	1	J16 JACKET	304 S/S	TOP COVER ASSEMBLY
7	1	J16 FRONT COVER	304 S/S	FRONT COVER ASSEMBLY
8	1	J16 BASE	304 S/S	BASE ASSEMBLY
9	1		FOAM	INSULATION
10	4	61649NOBN5T4	PLASTIC	ADJUSTABLE LEGS
11	6	N2375-10	INCOLOY SHEATH	HEATING ELEMENT - 1-7/8" HEX 9600W @ 208V
12	1	T1000	VARIOUS	CONTROL MODULE
13	2	C25FNF375B	VARIOUS	MAGNETIC CONTACTOR 90A (RESISTIVE) - 240V
14	1	KA4C	COPPER	GROUND LUG
15	1	J16 CONTROL PLATE	GALVANEEL	ELECTRICAL MOUNTING PANEL
16	1	TD1000	VARIOUS	DIGITAL DISPLAY MODULE
17	1	P65	VARIOUS	PROBE ASSEMBLY
18	1	OVERLAY J MODEL	LEXAN	OVERLAY FOR DISPLAY MODULE
19	1		VARIOUS	LEAK DETECTION SENSOR
20	1	TTD405	VARIOUS	T&P GAUGE 30-240°F/0-200PSI
21	1	N45BU	BRONZE	PRESS REDUCING VALVE 25-75PSI
22	1	PDB310-1X6-3	VARIOUS	POWER DISTRIBUTION BLOCK 310A, 3-POLE, 1 PRIM., 6 SEC.
23	2	CB 100 AMP	VARIOUS	POWER CIRCUIT BREAKER 100A, 3-POLE, 240V

REVISIONS				
ZONE	REV.	DESCRIPTION	DATE	APPROVED

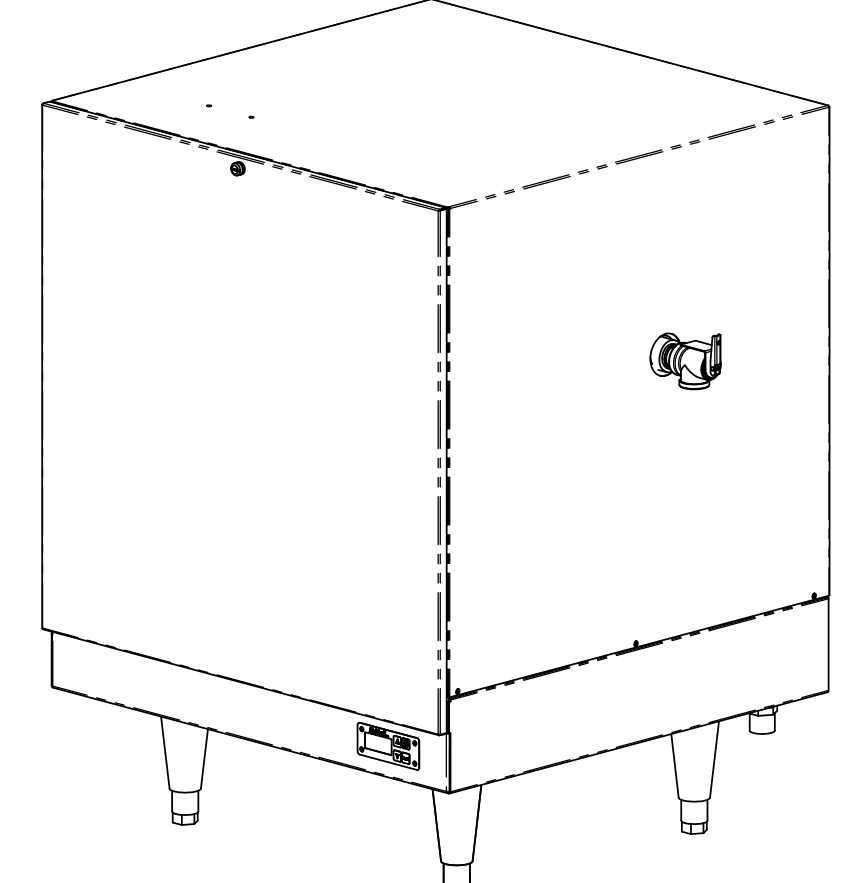
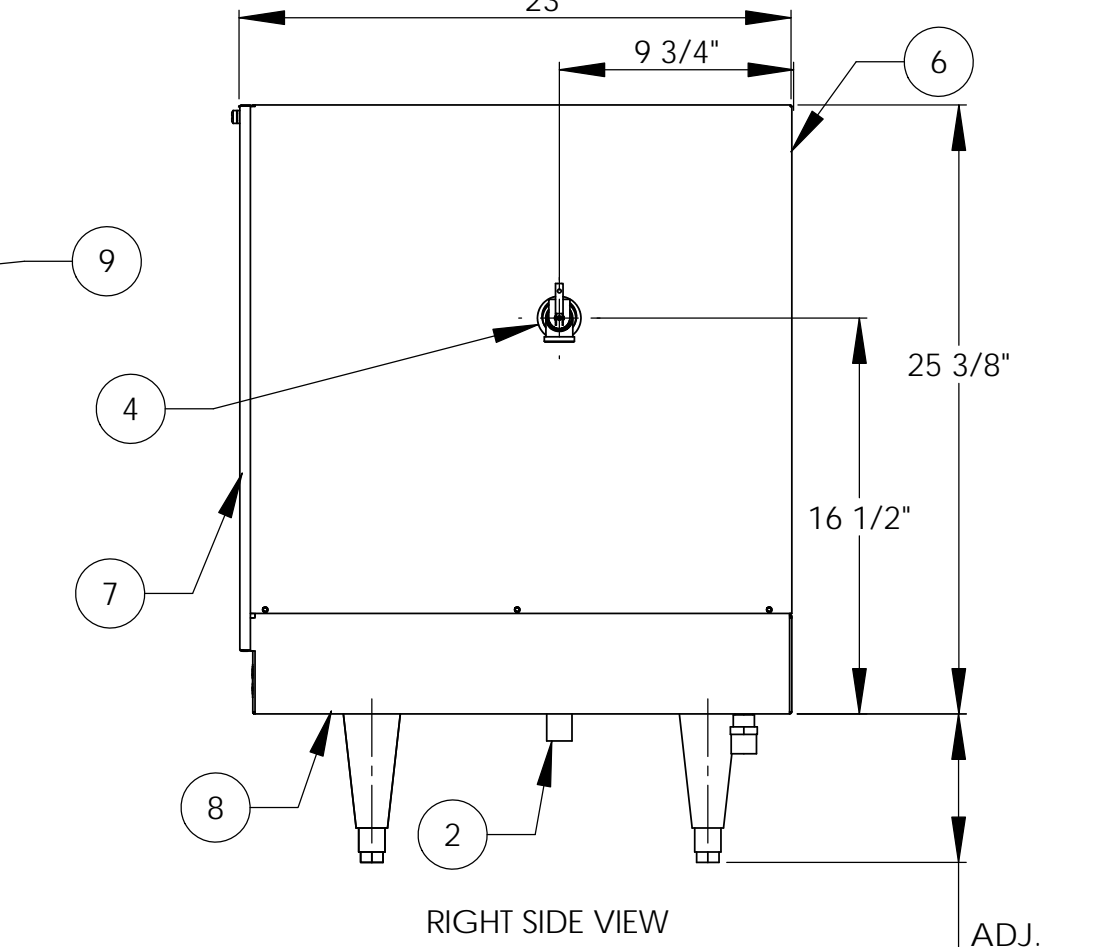
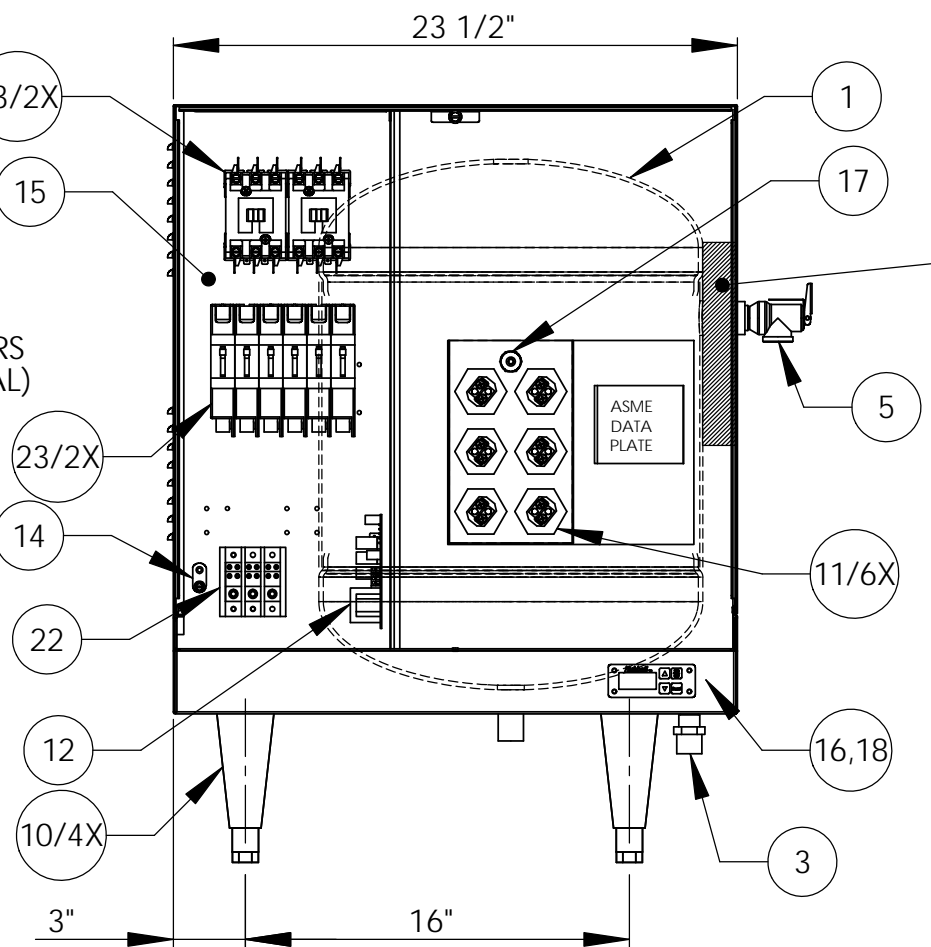
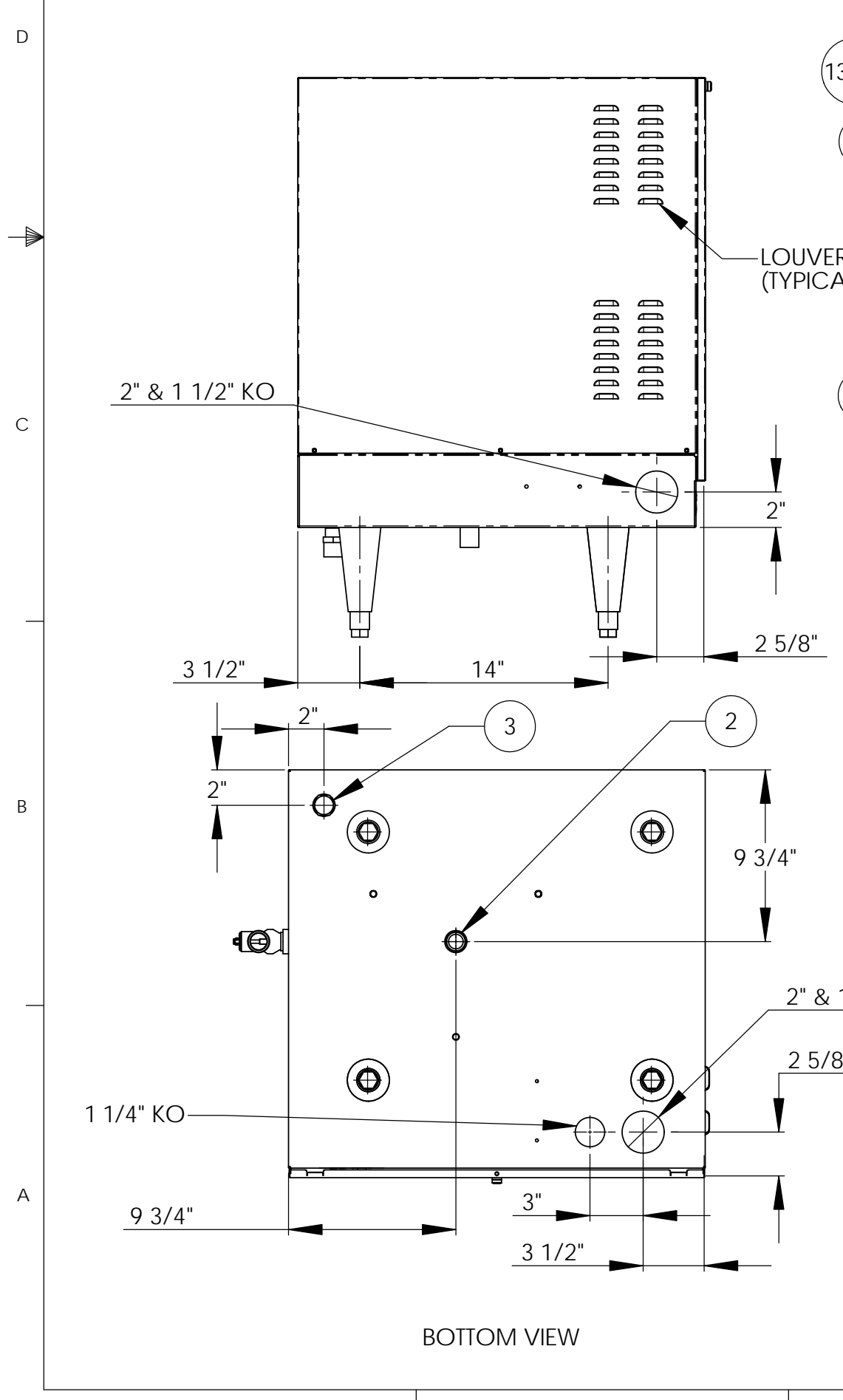

INSTALLATION REQUIREMENTS	
AMP Draw	162.4
Min. Breaker/Fuse Size	200 AMP
Cu Power Feed Wire	#4/0 AWG THHN
Min. Power Conduit	1 1/2"
Wiring Diagram	12

ELECTRICAL NOTES:
 1. POWER FEED WIRE SIZING IS BASED ON 75 °C Cu THHN WIRE WITH FEEDER BRANCH PROTECTION AT 125%.
 2. REFERENCE INSTALLATION, OPERATION, AND MAINTENANCE MANUAL FOR COMPLETE INSTALLATION INSTRUCTIONS.

- NOTES:**
- TANK IS DESIGNED, FABRICATED, AND STAMPED IAW ASME SECTION VIII CODE, LATEST ADDENDA.
 - TANK IS DESIGNED FOR 150PSI AND PRESSURE TESTED AT 225PSI.
 - PROBE ASSEMBLY (Pc. No. 17) PROVIDES TEMPERATURE CONTROL, HI-LIMIT, AND LOW WATER SENSING.
 - UNIT IS UL, CUL, AND UL EPH LISTED.
 - PIECE NOS. 5, 10, 20, & 21 ARE SHIPPED LOOSE.
 - CONTROL CIRCUIT WIRE TO BE #18 TEFZEL 750 (200°C), POWER CIRCUIT WIRE TO BE #6 TEFZEL 750 (200°C), ELEMENT JUMPER WIRE TO BE #8 TEFZEL 750 (200°C).
 - PHASE TO PHASE RESISTANCE: 1.5 OHMS
 - APPROXIMATE WEIGHT:
 DRY: 131 LBS.
 WET: 264 LBS.

DRAWN	2/26/03	PRD	Stratford, CT 06615 (203) 378-2659 The Electric Heater Company
CHECKED	2/26/03	WENIII	
ENG APPR.	2/26/03	PRD	
MFG APPR.	2/26/03	CHD	
Customer:			Description: J MODEL BOOSTER HEATER J1658R- 16 GALLON 58.5kW - 208V - 3Ø
SIZE	DWG. NO.	REV	
C	J1658R		
SCALE: 1:8	FSCM: 19857	SHEET 1 OF 1	

PROPRIETARY AND CONFIDENTIAL
 THE INFORMATION CONTAINED IN THIS DRAWING IS THE SOLE PROPERTY OF THE ELECTRIC HEATER COMPANY. ANY REPRODUCTION IN PART OR AS A WHOLE WITHOUT THE WRITTEN PERMISSION OF THE ELECTRIC HEATER COMPANY IS PROHIBITED.

DIMENSIONS ARE IN INCHES
 TOLERANCES:
 (UNLESS OTHERWISE SPECIFIED)
 FRACTIONAL ±1/16
 ANGULAR: MACH ±1/2° BEND ±1"
 TWO PLACE DECIMAL ±0.01
 THREE PLACE DECIMAL ±0.005