

ITEM NO.	QTY	PART NO.	MATERIAL	DESCRIPTION
1	1	J16-6 TANK	304 S/S	16 GALLON VESSEL ASSEMBLY
2	1	J16 INLET	304 S/S	3/4" MNPT INLET
3	1	J16 OUTLET	COPPER	3/4" MNPT OUTLET
4	1		304 S/S	3/4" FNPT FOR RELIEF VALVE
5	1	100XL 75 150LB	BRONZE	RELIEF VALVE SET AT 150PSI, 210°F
6	1	J16 JACKET	304 S/S	TOP COVER ASSEMBLY
7	1	J16 FRONT COVER	304 S/S	FRONT COVER ASSEMBLY
8	1	J16 BASE	304 S/S	BASE ASSEMBLY
9	1		FOAM	INSULATION
10	4	61649NOBN514	PLASTIC	ADJUSTABLE LEGS
11	6	N2375-21	BRASS PLUG & COPPER SHEATH	HEATING ELEMENT - 1-7/8" HEX 9750W @ 240V
12	1	T1000	VARIOUS	CONTROL MODULE
13	2	C25FNF375B	VARIOUS	MAGNETIC CONTACTOR 90A (RESISTIVE) - 240V
14	1	KA4C	COPPER	GROUND LUG
15	1	J16 CONTROL PLATE	GALVANEEL	ELECTRICAL MOUNTING PANEL
16	1	TD1000	VARIOUS	DIGITAL DISPLAY MODULE
17	1	P65	VARIOUS	PROBE ASSEMBLY
18	1	OVERLAY J MODEL	LEXAN	OVERLAY FOR DISPLAY MODULE
19	1		VARIOUS	LEAK DETECTION SENSOR
20	1	TTD405	VARIOUS	T&P GAUGE 30-240°F/0-200PSI
21	1	N45BU	BRONZE	PRESS REDUCING VALVE 25-75PSI
22	1	PDB310-1X6-3	VARIOUS	POWER DISTRIBUTION BLOCK 310A, 3-POLE, 1 PRIM., 6 SEC.
23	2	CB 90 AMP	VARIOUS	POWER CIRCUIT BREAKER 90A, 3-POLE, 240V

REVISIONS		DATE	APPROVED

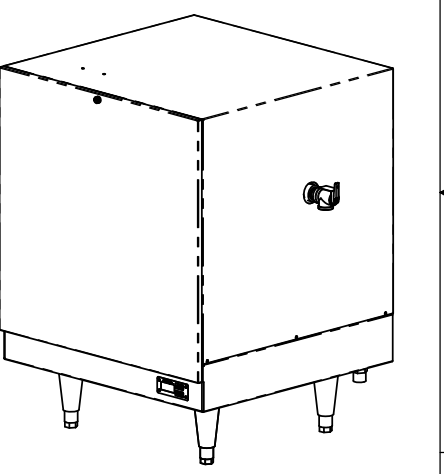

- NOTES:
- TANK IS DESIGNED, FABRICATED, AND STAMPED IAW ASME SECTION VIII CODE, LATEST ADDENDA.
 - TANK IS DESIGNED FOR 150PSI AND PRESSURE TESTED AT 225PSI.
 - PROBE ASSEMBLY (Pc. No. 17) PROVIDES TEMPERATURE CONTROL, HI-LIMIT, AND LOW WATER SENSING.
 - UNIT IS UL, CUL, AND UL EPH LISTED.
 - PIECE NOS. 5, 10, 20, & 21 ARE SHIPPED LOOSE.
 - CONTROL CIRCUIT WIRE TO BE #18 TEFZEL 750 (200°C), POWER CIRCUIT WIRE TO BE #6 TEFZEL 750 (200°C), ELEMENT JUMPER WIRE TO BE #8 TEFZEL 750 (200°C).
 - PHASE TO PHASE RESISTANCE: 2.0 OHMS
 - APPROXIMATE WEIGHT:
DRY: 131 LBS.
WET: 264 LBS.

INSTALLATION REQUIREMENTS	
AMP Draw	140.7
Min. Breaker/Fuse Size	180 AMP
Cu Power Feed Wire	#2/0 AWG THHN
Min. Power Conduit	1 1/2"
Wiring Diagram	12

ELECTRICAL NOTES:

- POWER FEED WIRE SIZING IS BASED ON 75°C Cu THHN WIRE WITH FEEDER BRANCH PROTECTION AT 125%.
- REFERENCE INSTALLATION, OPERATION, AND MAINTENANCE MANUAL FOR COMPLETE INSTALLATION INSTRUCTIONS.

<small>PROPRIETARY AND CONFIDENTIAL</small> THE INFORMATION CONTAINED IN THIS DRAWING IS THE SOLE PROPERTY OF THE ELECTRIC HEATER COMPANY. ANY REPRODUCTION IN PART OR AS A WHOLE WITHOUT THE WRITTEN PERMISSION OF THE ELECTRIC HEATER COMPANY IS PROHIBITED.		DIMENSIONS ARE IN INCHES TOLERANCES: (UNLESS OTHERWISE SPECIFIED) FRACTIONAL: 1/16" ANGULAR: MACH ±1/2° BEND ±1° TWO PLACE DECIMAL: ±0.01 THREE PLACE DECIMAL: ±0.005
DRAWN: 2/26/03 PRD CHECKED: 2/26/03 WEN/III ENG APPR: 2/26/03 PRD MFG APPR: 2/26/03 CHD	DATE: 2/26/03 NAME: WEN/III PRD CHD	Hubbell Stratford, CT 06615 (203) 378-2659 The Electric Heater Company Customer: Description: J MODEL BOOSTER HEATER J1658T- 16 GALLON 58.5KW - 240V - 3Ø
SIZE: C DWG. NO: J1658T SCALE: 1:8 FSCM: 19857	REV: 1 SHEET 1 OF 1	SHEET 1 OF 1