

58.5kW - 480V - 3Ø - 70.4A

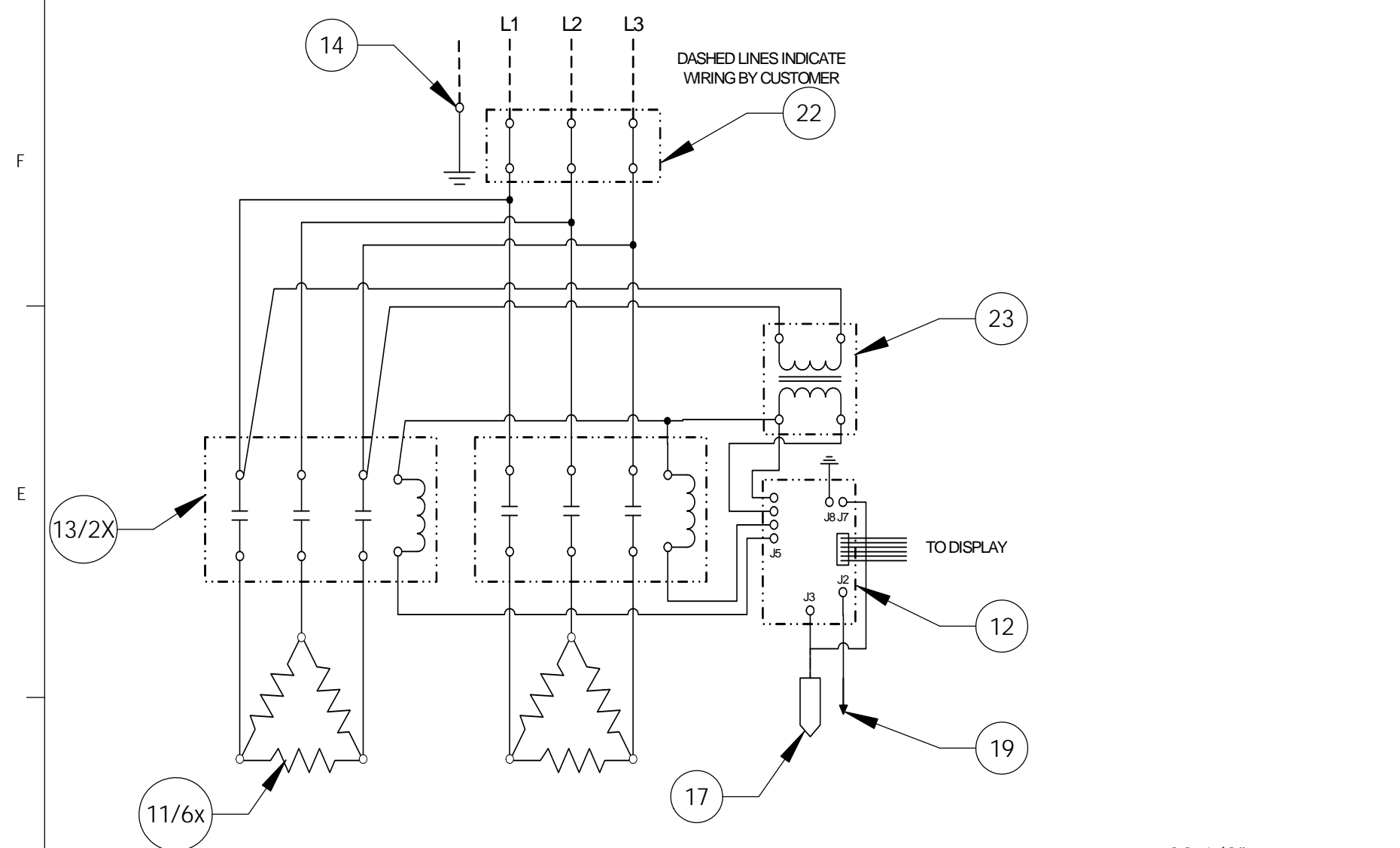

ITEM NO.	QTY.	PART NO.	MATERIAL	DESCRIPTION
1	1	J16-6 TANK	304L S/S	16 GALLON VESSEL ASSEMBLY
2	1	J16 INLET	304 S/S	3/4" MNPT INLET
3	1	J16 OUTLET	COPPER	3/4" MNPT OUTLET
4	1		304L S/S	3/4" FNPT FOR RELIEF VALVE
5	1	100XL .75 150LB	BRONZE	RELIEF VALVE SET AT 150PSI, 210°F
6	1	J16 JACKET	304 S/S	TOP COVER ASSEMBLY
7	1	J16 FRONT COVER	304 S/S	FRONT COVER ASSEMBLY
8	1	J16 BASE	304 S/S	BASE ASSEMBLY
9	1		FOAM	FOAM INSULATION
10	4	AP61-4003-C	PLASTIC	ADJUSTABLE LEGS
11	6	N2375-33	BRASS PLUG & INCOLOY SHEATH	HEATING ELEMENT - 1-7/8" HEX 9750W @ 480V
12	1	T1000	VARIOUS	CONTROL MODULE
13	2	C25DNF330B	VARIOUS	MAGNETIC CONTACTOR 40A (RESISTIVE) - 240V
14	1	KA4C	COPPER	GROUND LUG
15	1	J16 CONTROL PLATE	GALVANEEL	ELECTRICAL MOUNTING PANEL
16	1	TD1000	VARIOUS	DIGITAL DISPLAY MODULE
17	1	P65	VARIOUS	PROBE ASSEMBLY
18	1	OVERLAY J MODEL	LEXAN	OVERLAY FOR DISPLAY MODULE
19	1		VARIOUS	LEAK DETECTION SENSOR
20	1	TTD405	VARIOUS	T&P GAUGE 30-240°F/0-200PSI
21	1	N45BU	BRONZE	PRESS REDUCING VALVE 25-75PSI
22	1	PDB175-1X4-3	VARIOUS	POWER DISTRIBUTION BLOCK 175A, 3-POLE, 1 PRIM., 4 SEC.
23	1	B050-3299-3	VARIOUS	TRANSFORMER 50VA 480-208/240V

REVISIONS				
ZONE	REV.	DESCRIPTION	DATE	APPROVED
	-	---	---	---

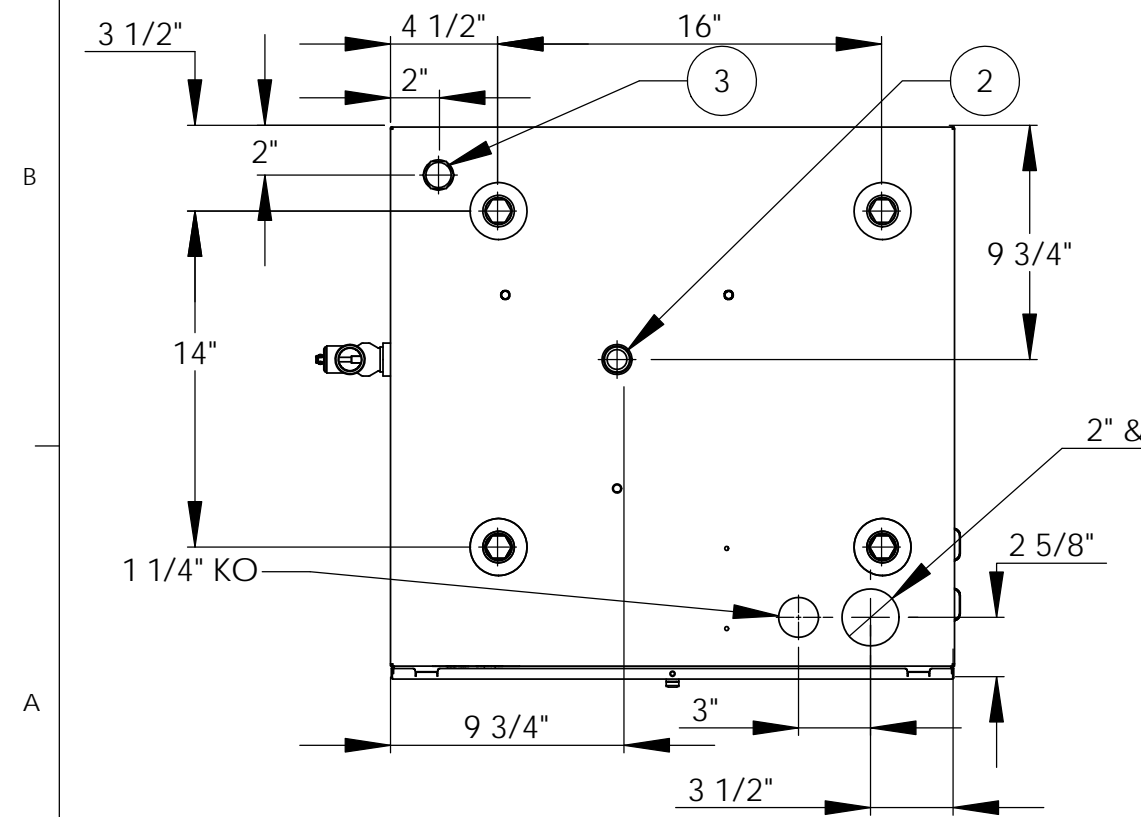
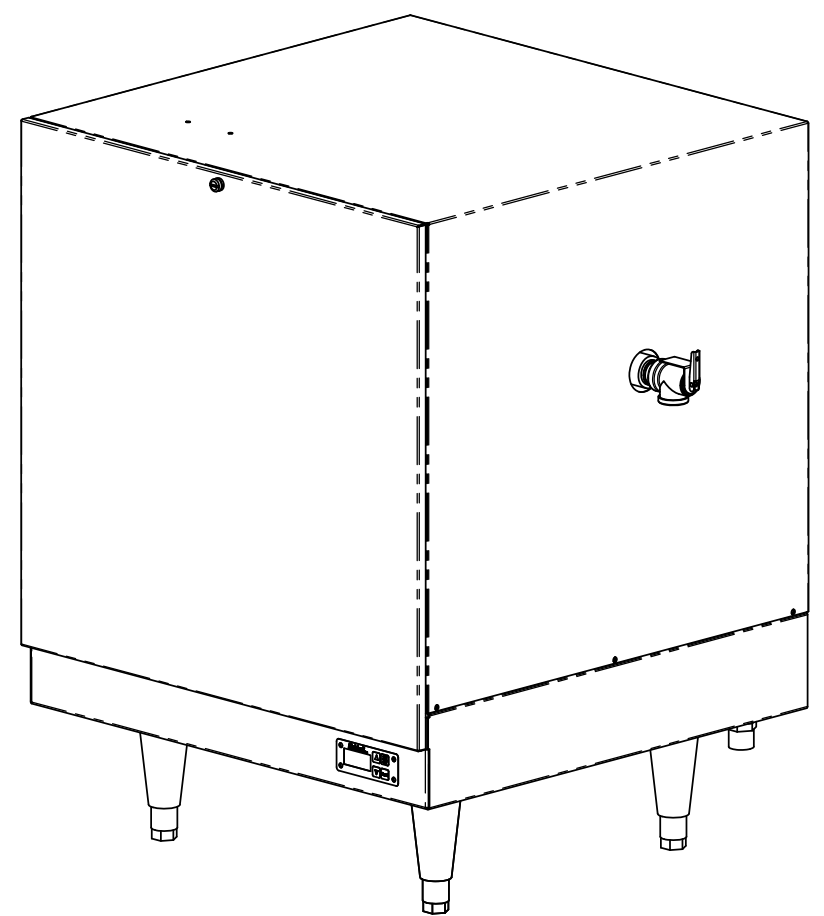
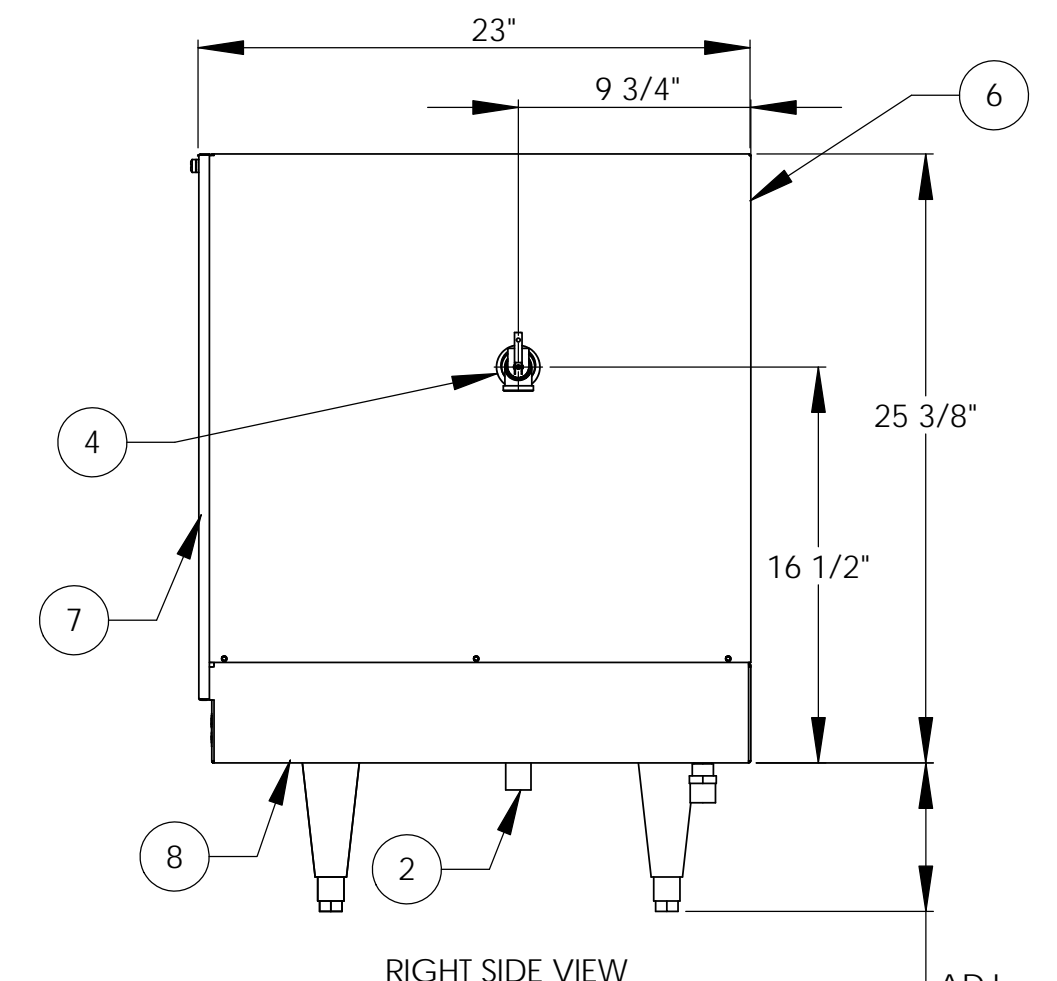
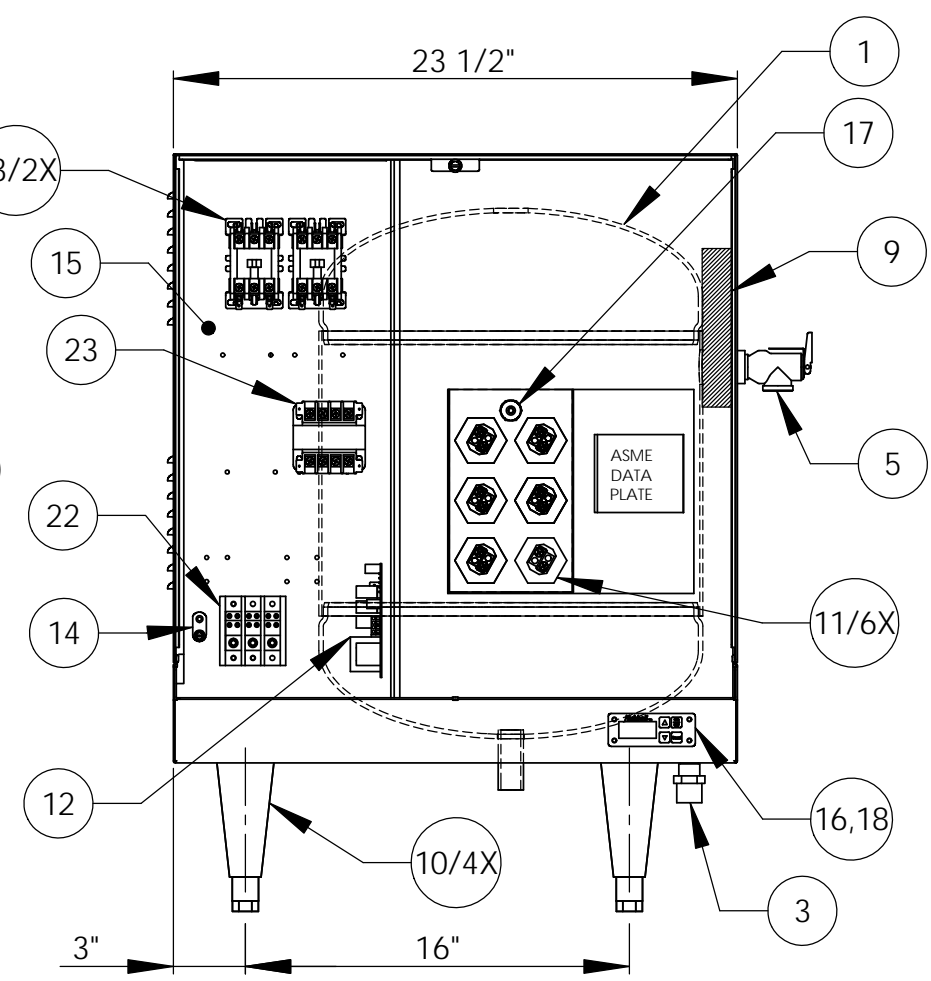
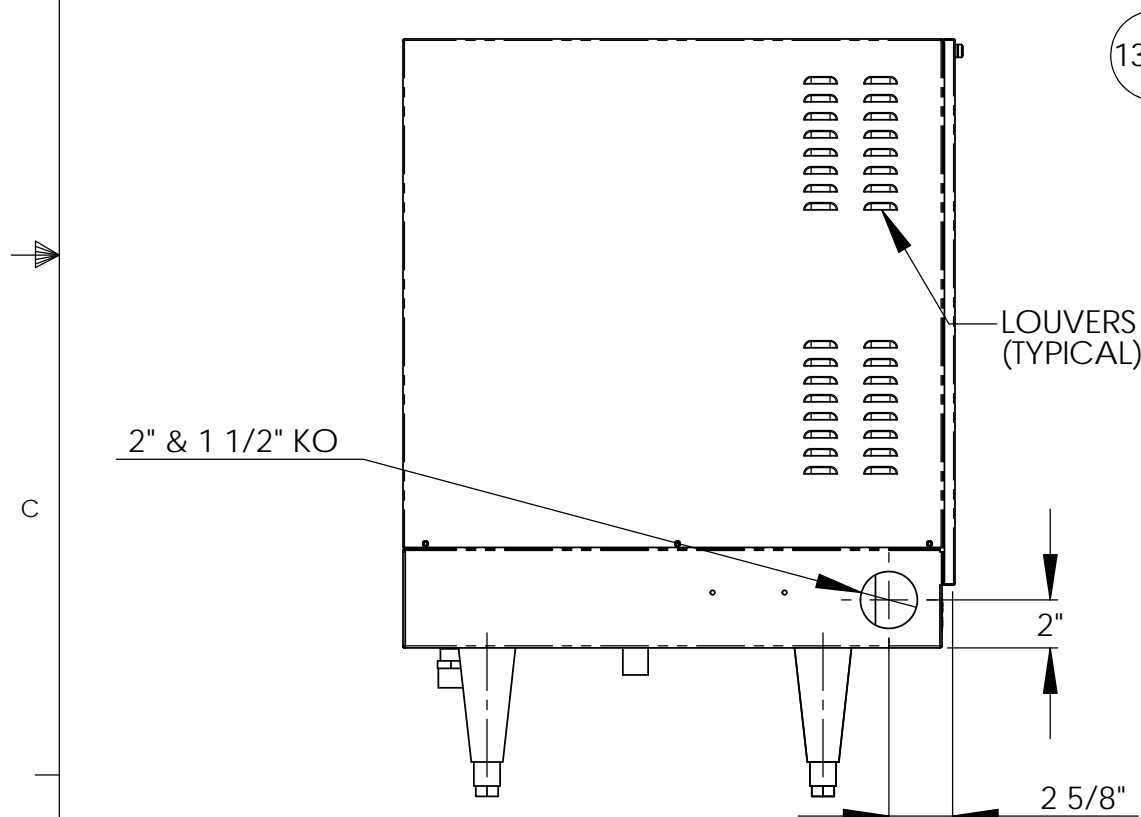

FRONT VIEW (WITH COVER REMOVED)

RIGHT SIDE VIEW

ADJ. 6" TO 8"

BOTTOM VIEW

INSTALLATION REQUIREMENTS	
AMP Draw	70.4
Min. Breaker/Fuse Size	90 AMP
Cu Power Feed Wire	#3 AWG THHN
Min. Power Conduit	1"
Wiring Diagram	12 (WT)

ELECTRICAL NOTES:
 1. POWER FEED WIRE SIZING IS BASED ON 75 °C Cu THHN WIRE WITH FEEDER BRANCH PROTECTION AT 125%.
 2. REFERENCE INSTALLATION, OPERATION, AND MAINTENANCE MANUAL FOR COMPLETE INSTALLATION INSTRUCTIONS.

PROPRIETARY AND CONFIDENTIAL
 THE INFORMATION CONTAINED IN THIS DRAWING IS THE SOLE PROPERTY OF THE ELECTRIC HEATER COMPANY. ANY REPRODUCTION IN PART OR AS A WHOLE WITHOUT THE WRITTEN PERMISSION OF THE ELECTRIC HEATER COMPANY IS PROHIBITED.

DIMENSIONS ARE IN INCHES
 TOLERANCES:
 (UNLESS OTHERWISE SPECIFIED)
 FRACTIONAL ±1/16
 ANGULAR: MACH ±1/2° BEND ±1°
 TWO PLACE DECIMAL ±0.01
 THREE PLACE DECIMAL ±0.005

- NOTES:**
- TANK IS DESIGNED, FABRICATED, AND STAMPED IAW ASME SECTION VIII CODE, LATEST ADDENDA.
 - TANK IS DESIGNED FOR 150PSI AND PRESSURE TESTED AT 225PSI.
 - PROBE ASSEMBLY (Pc. No. 17) PROVIDES TEMPERATURE CONTROL, HI-LIMIT, AND LOW WATER SENSING. UNIT IS UL, CUL, AND UL EPH LISTED.
 - PIECE NOS. 5, 10, 20, & 21 ARE SHIPPED LOOSE.
 - CONTROL CIRCUIT WIRE TO BE #18 TEFZEL 750 (200°C), POWER CIRCUIT WIRE TO BE #12 TEFZEL 750 (200°C), ELEMENT JUMPER WIRE TO BE #12 TEFZEL 750 (200°C).
 - PHASE TO PHASE RESISTANCE: 7.9 OHMS.
 - APPROXIMATE WEIGHT:
 DRY: 131 LBS.
 WET: 264 LBS.

DATE	NAME	
2/26/03	PRD	DRAWN
2/26/03	WENIII	CHECKED
2/26/03	PRD	ENG APPR.
2/26/03	CHD	MFG APPR.

Hubbell Stratford, CT 06615 (203) 378-2659
The Electric Heater Company

Customer: J MODEL BOOSTER HEATER
 J165814 - 16 GALLON
 58.5kW - 480V - 3Ø

SIZE	DWG. NO.	REV
C	J165814	-

SCALE: 1:8 | FSCM: 19857 | SHEET 1 OF 1