

6kW - 208V - 3Ø - 16.7A

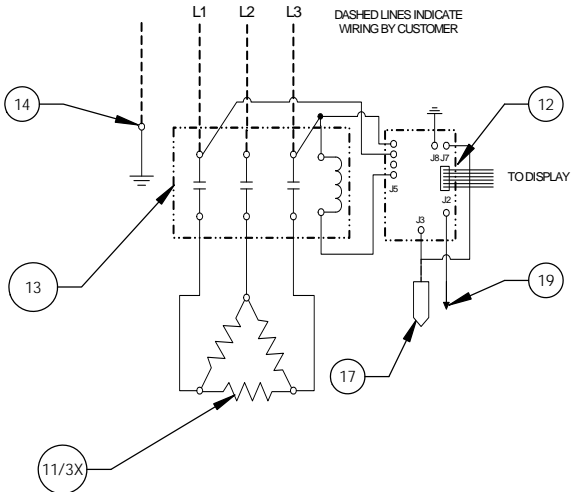

ITEM NO.	QTY	PART NO.	MATERIAL	DESCRIPTION
1	1	J16-6 TANK	304L S/S	16 GALLON VESSEL ASSEMBLY
2	1	J16 INLET	304 S/S	3/4" MNPT INLET
3	1	J16 OUTLET	COPPER	3/4" MNPT OUTLET
4	1		304L S/S	3/4" FNPT FOR RELIEF VALVE
5	1	100XL 75 150LB	BRONZE	RELIEF VALVE SET AT 150PSI, 210°F
6	1	J16 JACKET	304 S/S	TOP COVER ASSEMBLY
7	1	J16 FRONT COVER	304 S/S	FRONT COVER ASSEMBLY
8	1	J16 BASE	304 S/S	BASE ASSEMBLY
9	1		FOAM	INSULATION
10	4	61649NOBN514	PLASTIC	ADJUSTABLE LEGS
11	3	C1315-2	BRASS PLUG & COPPER SHEATH	HEATING ELEMENT - 1-7/8" HEX 2000W @ 208V
12	1	T1000	VARIOUS	CONTROL MODULE
13	1	C25DNF330B	VARIOUS	MAGNETIC CONTACTOR 40A (RESISTIVE) - 240V
14	1	K8C	COPPER	GROUND LUG
15	1	J16 CONTROL PLATE	GALVANEEL	ELECTRICAL MOUNTING PANEL
16	1	ID1000	VARIOUS	DIGITAL DISPLAY MODULE
17	1	P65	VARIOUS	PROBE ASSEMBLY
18	1	OVERLAY J MODEL	LEXAN	OVERLAY FOR DISPLAY MODULE
19	1		VARIOUS	LEAK DETECTION SENSOR
20	1	ITD405	VARIOUS	T&P GAUGE 30-240°F/0-200PSI
21	1	N45BU	BRONZE	PRESS REDUCING VALVE 25-75PSI

ZONE		REV		REVISIONS		DATE	APPROVED
				DESCRIPTION			

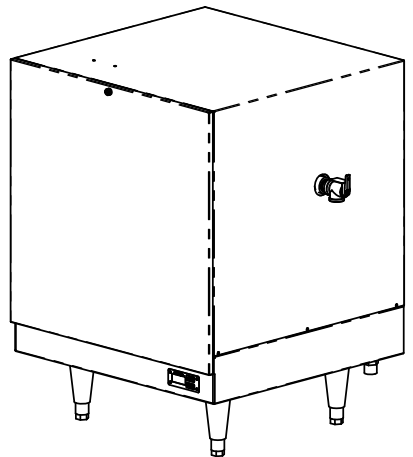
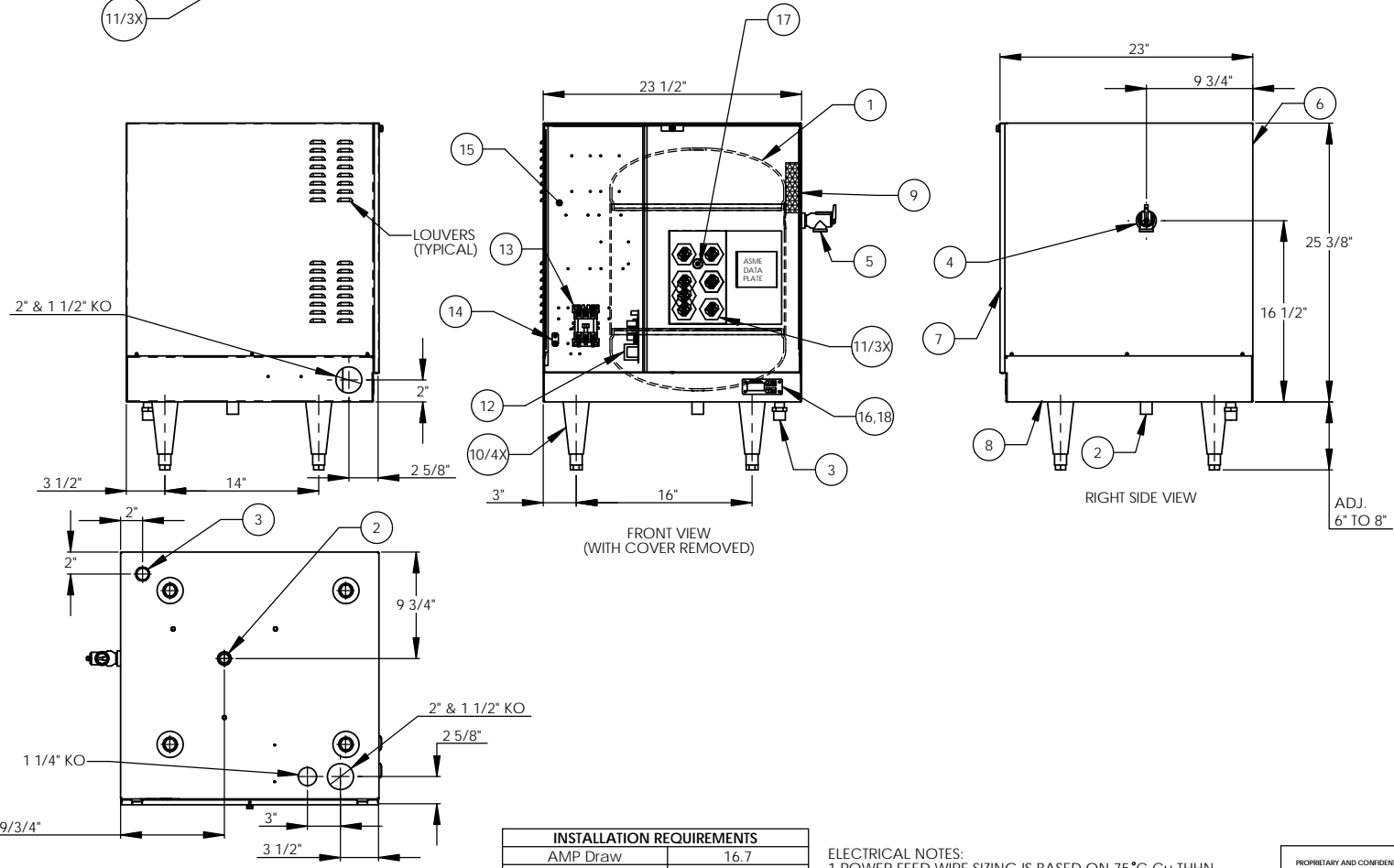

- NOTES:
- TANK IS DESIGNED, FABRICATED, AND STAMPED IAW ASME SECTION VIII CODE, LATEST ADDENDA.
 - TANK IS DESIGNED FOR 150PSI AND PRESSURE TESTED AT 225PSI.
 - PROBE ASSEMBLY (Pc. No. 17) PROVIDES TEMPERATURE CONTROL, HI-LIMIT, AND LOW WATER SENSING.
 - UNIT IS UL, CUL, AND UL EPH LISTED.
 - PIECE NOS. 5, 10, 20, & 21 ARE SHIPPED LOOSE.
 - CONTROL CIRCUIT WIRE TO BE #18 TEFZEL 750 (200°C), POWER CIRCUIT WIRE TO BE #12 TEFZEL 750 (200°C), ELEMENT JUMPER WIRE TO BE #12 TEFZEL 750 (200°C).
 - PHASE TO PHASE RESISTANCE: 14.4 OHMS
 - APPROXIMATE WEIGHT: DRY: 128 LBS. WET: 261 LBS.

INSTALLATION REQUIREMENTS	
AMP Draw	16.7
Min. Breaker/Fuse Size	25 AMP
Cu Power Feed Wire	#10 AWG THHN
Min. Power Conduit	1/2"
Wiring Diagram	10 (NT)

ELECTRICAL NOTES:
 1. POWER FEED WIRE SIZING IS BASED ON 75°C Cu THHN WIRE WITH FEEDER BRANCH PROTECTION AT 125%.
 2. REFERENCE INSTALLATION, OPERATION, AND MAINTENANCE MANUAL FOR COMPLETE INSTALLATION INSTRUCTIONS.

PROPRIETARY AND CONFIDENTIAL
 THE INFORMATION CONTAINED IN THIS DRAWING IS THE SOLE PROPERTY OF THE ELECTRIC HEATER COMPANY. ANY REPRODUCTION IN PART OR AS A WHOLE WITHOUT THE WRITTEN PERMISSION OF THE ELECTRIC HEATER COMPANY IS PROHIBITED.

DIMENSIONS ARE IN INCHES TOLERANCES: (UNLESS OTHERWISE SPECIFIED) FRACTIONAL: 1/16" ANGULAR: MACH 1/16" BEND ±1" TWO PLACE DECIMAL: ±0.01 THREE PLACE DECIMAL: ±0.005

DRAWN	2/26/03	PRD	Stratford, CT 06615 (203) 378-2659 The Electric Heater Company
CHECKED	2/26/03	WEN/ML	
ENG APPR	2/26/03	PRD	
MFG APPR	2/26/03	CHD	
Customer:			Description: J MODEL BOOSTER HEATER
			J166R - 16 GALLON 6kW - 208V - 3Ø
SIZE	DWG. NO.	REV	
C	J166R		
SCALE: 1:8	FSCM: 19857	SHEET 1 OF 1	