

6kW - 480V - 3Ø - 7.2A

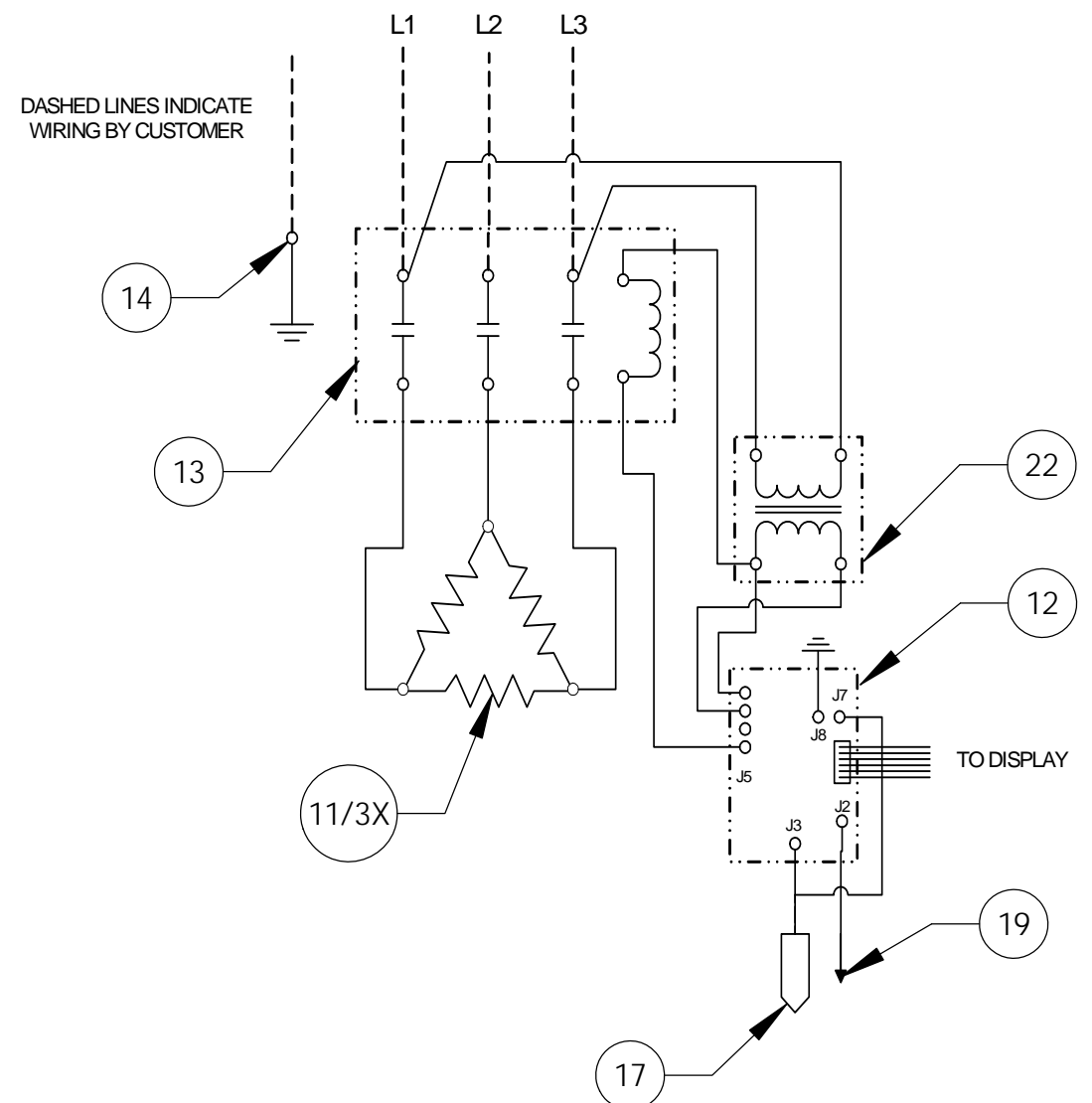

ITEM NO.	QTY.	PART NO.	MATERIAL	DESCRIPTION
1	1	J16-6 TANK	304L S/S	16 GALLON VESSEL ASSEMBLY
2	1	J16 INLET	304 S/S	3/4" MNPT INLET
3	1	J16 OUTLET	COPPER	3/4" MNPT OUTLET
4	1		304L S/S	3/4" FNPT FOR RELIEF VALVE
5	1	100XL .75 150LB	BRONZE	RELIEF VALVE SET AT 150PSI, 210°F
6	1	J16 JACKET	304 S/S	TOP COVER ASSEMBLY
7	1	J16 FRONT COVER	304 S/S	FRONT COVER ASSEMBLY
8	1	J16 BASE	304 S/S	BASE ASSEMBLY
9	1		FOAM	INSULATION
10	4	61649NOBN5T4	PLASTIC	ADJUSTABLE LEGS
11	3	C1315-22	BRASS PLUG & COPPER SHEATH	HEATING ELEMENT - 1-7/8" HEX 2000W @ 480V
12	1	T1000	VARIOUS	CONTROL MODULE
13	1	C25DNF315B	VARIOUS	MAGNETIC CONTACTOR 20A (RESISTIVE) - 240V
14	1	KA8C	COPPER	GROUND LUG
15	1	J16 CONTROL PLATE	GALVANEEL	ELECTRICAL MOUNTING PANEL
16	1	TD1000	VARIOUS	DIGITAL DISPLAY MODULE
17	1	P65	VARIOUS	PROBE ASSEMBLY
18	1	OVERLAY J MODEL	LEXAN	OVERLAY FOR DISPLAY MODULE
19	1		VARIOUS	LEAK DETECTION SENSOR
20	1	TTD405	VARIOUS	T&P GAUGE 30-240°F/0-200PSI
21	1	N45BU	BRONZE	PRESS REDUCING VALVE 25-75PSI
22	1	B050-3299-3	VARIOUS	TRANSFORMER 50VA 480-208/240V

REVISIONS				
ZONE	REV.	DESCRIPTION	DATE	APPROVED

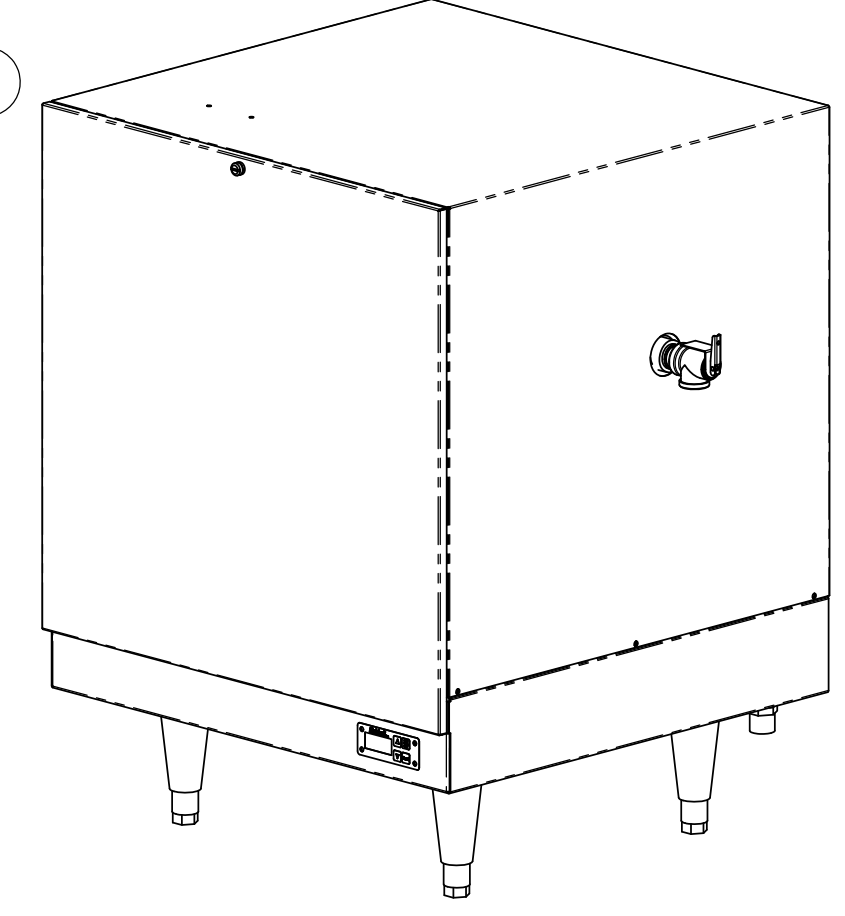
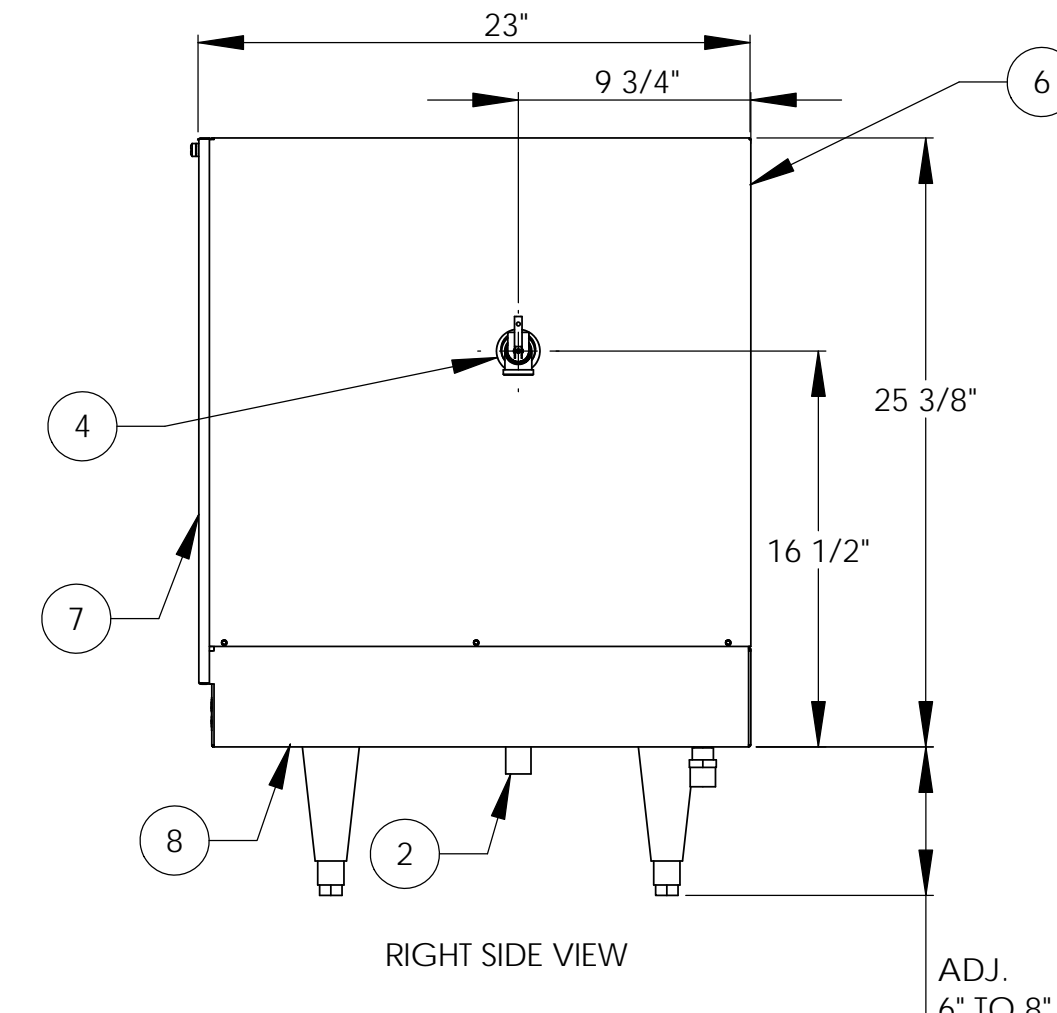
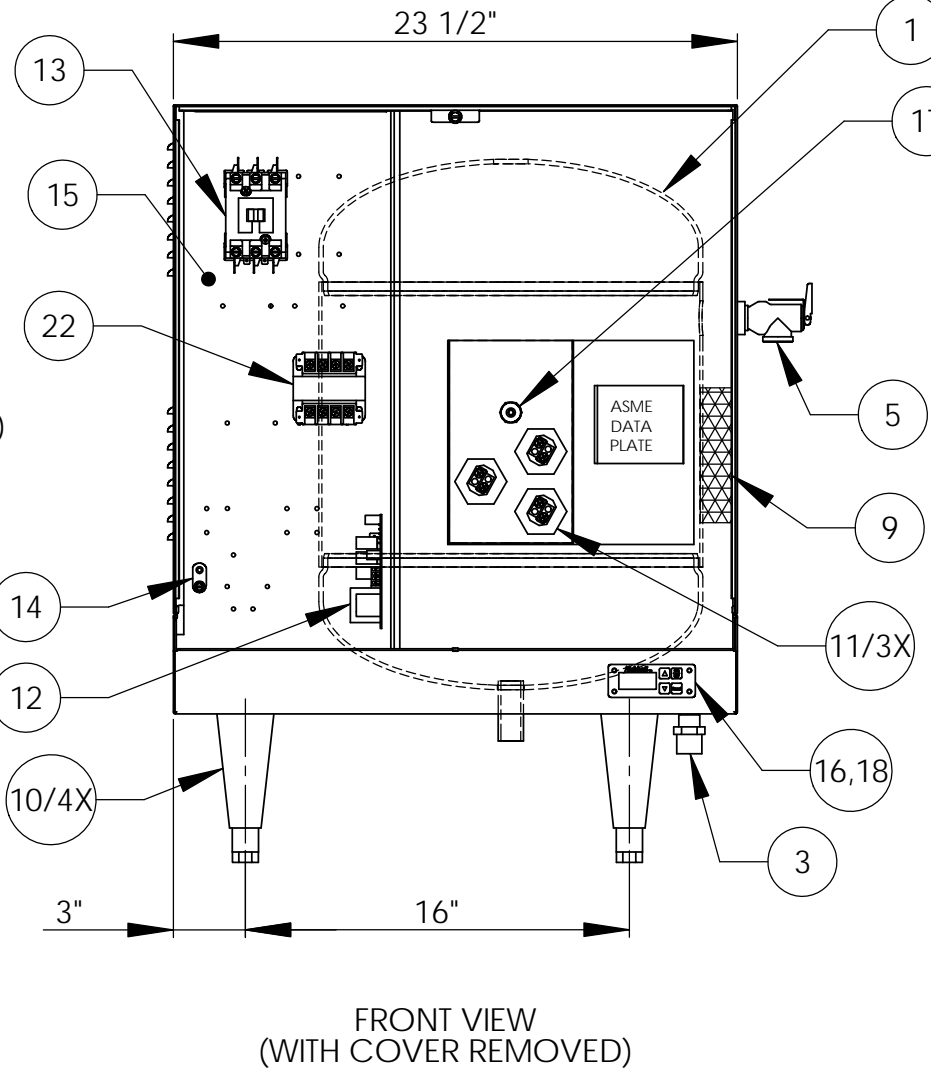
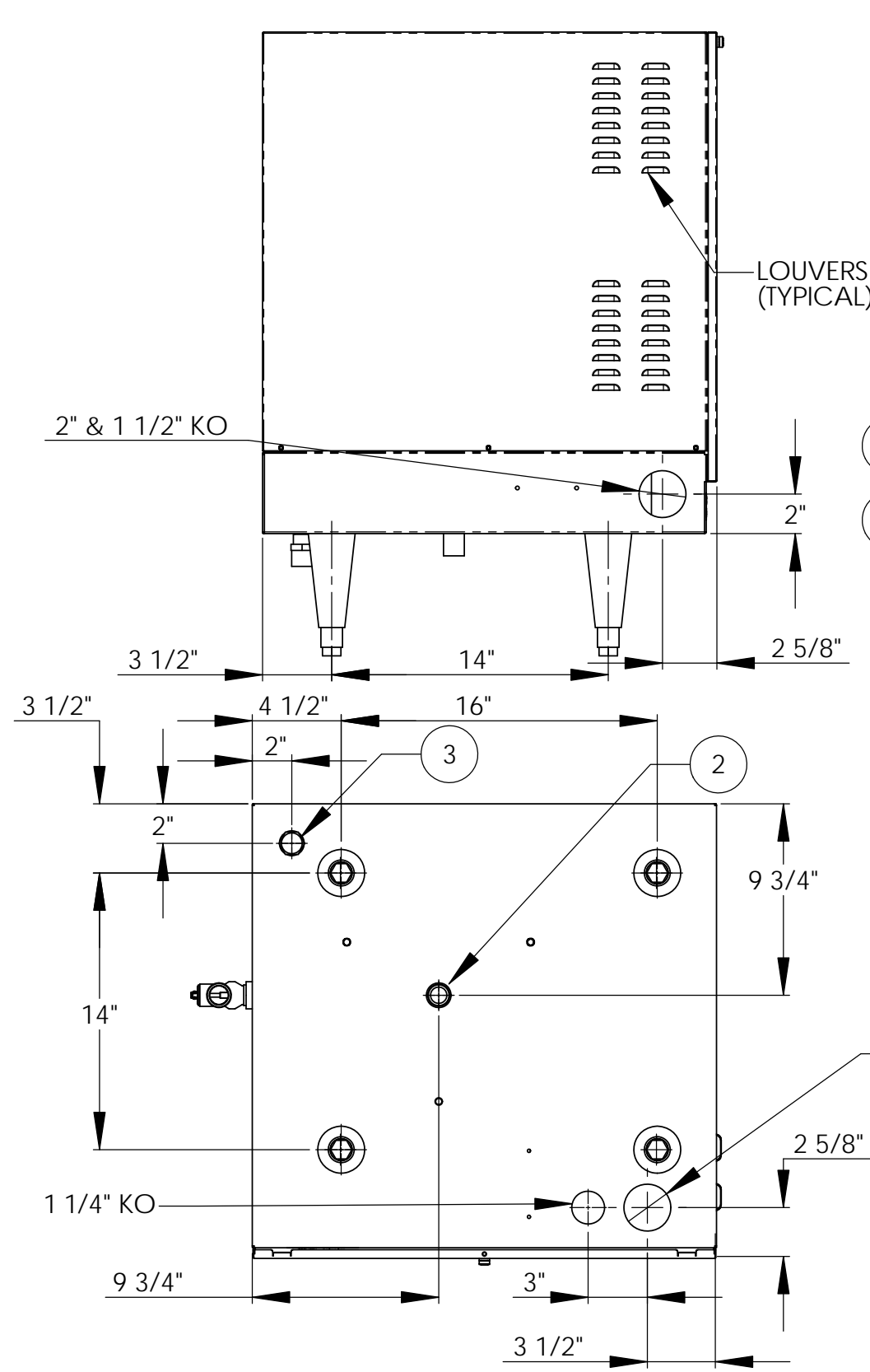

INSTALLATION REQUIREMENTS	
AMP Draw	7.2
Min. Breaker/Fuse Size	10 AMP
Cu Power Feed Wire	#14 AWG THHN
Min. Power Conduit	1/2"
Wiring Diagram	10(WT)

**ELECTRICAL NOTES:**  
 1. POWER FEED WIRE SIZING IS BASED ON 75 °C Cu THHN WIRE WITH FEEDER BRANCH PROTECTION AT 125%.  
 2. REFERENCE INSTALLATION, OPERATION, AND MAINTENANCE MANUAL FOR COMPLETE INSTALLATION INSTRUCTIONS.

- NOTES:**
- TANK IS DESIGNED, FABRICATED, AND STAMPED IAW ASME SECTION VIII CODE, LATEST ADDENDA.
  - TANK IS DESIGNED FOR 150PSI AND PRESSURE TESTED AT 225PSI.
  - PROBE ASSEMBLY (Pc. No. 17) PROVIDES TEMPERATURE CONTROL, HI-LIMIT, AND LOW WATER SENSING.
  - UNIT IS UL, CUL, AND UL EPH LISTED.
  - PIECE NOS. 5, 10, 20, & 21 ARE SHIPPED LOOSE.
  - CONTROL CIRCUIT WIRE TO BE #18 TEFZEL 750 (200°C). POWER CIRCUIT WIRE TO BE #12 TEFZEL 750 (200°C). ELEMENT JUMPER WIRE TO BE #12 TEFZEL 750 (200°C).
  - PHASE TO PHASE RESISTANCE: 76.8 OHMS
  - APPROXIMATE WEIGHT:  
 DRY: 128 LBS.  
 WET: 261 LBS.

DATE	NAME	
2/26/03	PRD	Stratford, CT 06615 (203) 378-2659 <b>The Electric Heater Company</b>
2/26/03	WENIII	
2/26/03	PRD	
2/26/03	CHD	
Customer: Description: J MODEL BOOSTER HEATER J166T4 - 16 GALLON 6kW - 480V - 3Ø		
SIZE	DWG. NO.	REV
C	J166T4	
SCALE: 1:8	FSCM: 19857	SHEET 1 OF 1

**PROPRIETARY AND CONFIDENTIAL**  
 THE INFORMATION CONTAINED IN THIS DRAWING IS THE SOLE PROPERTY OF THE ELECTRIC HEATER COMPANY. ANY REPRODUCTION IN PART OR AS A WHOLE WITHOUT THE WRITTEN PERMISSION OF THE ELECTRIC HEATER COMPANY IS PROHIBITED.

DIMENSIONS ARE IN INCHES  
 TOLERANCES:  
 (UNLESS OTHERWISE SPECIFIED)  
 FRACTIONAL ±1/16  
 ANGULAR: MACH ±1/2° BEND ±1°  
 TWO PLACE DECIMAL ±0.01  
 THREE PLACE DECIMAL ±0.005