

7kW - 240V - 3Ø - 16.8A

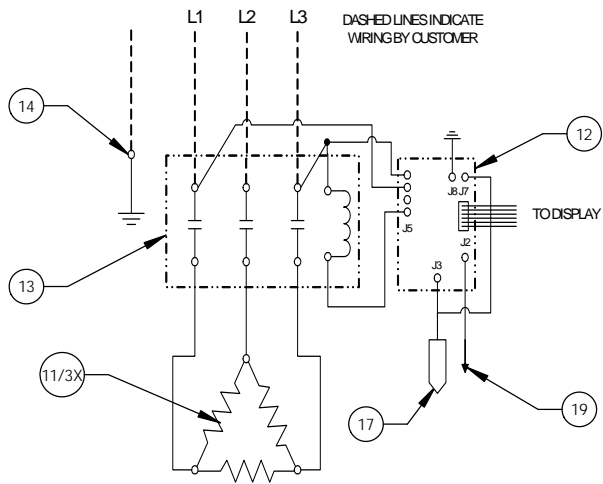

ITEM NO.	QTY	PART NO.	MATERIAL	DESCRIPTION
1	1	J16-6 TANK	304 S/S	16 GALLON VESSEL ASSEMBLY
2	1	J16 INLET	304 S/S	3/4" MNPT INLET
3	1	J16 OUTLET	COPPER	3/4" MNPT OUTLET
4	1		304 S/S	3/4" FNPT FOR RELIEF VALVE
5	1	100XL 75 150LB	BRONZE	RELIEF VALVE SET AT 150PSI, 210°F
6	1	J16 JACKET	304 S/S	TOP COVER ASSEMBLY
7	1	J16 FRONT COVER	304 S/S	FRONT COVER ASSEMBLY
8	1	J16 BASE	304 S/S	BASE ASSEMBLY
9	1		FOAM	INSULATION
10	4	61649NOBN5T4	PLASTIC	ADJUSTABLE LEGS
11	3	C1315-2	BRASS PLUG & COPPER SHEATH	HEATING ELEMENT 1-7/8" HEX 2000W@208V / 2660W@240V
12	1	T1000	VARIOUS	CONTROL MODULE
13	1	C25DNF330B	VARIOUS	MAGNETIC CONTACTOR 40A (RESISTIVE) - 240V
14	1	KA8C	COPPER	GROUND LUG
15	1	J16 CONTROL PLATE	GALVANEEL	ELECTRICAL MOUNTING PANEL
16	1	TD1000	VARIOUS	DIGITAL DISPLAY MODULE
17	1	P65	VARIOUS	PROBE ASSEMBLY
18	1	OVERLAY J MODEL	LEXAN	OVERLAY FOR DISPLAY MODULE
19	1		VARIOUS	LEAK DETECTION SENSOR
20	1	TTD405	VARIOUS	T&P GAUGE 3Ø-240°F/0-200PSI
21	1	N45BU	BRONZE	PRESS REDUCING VALVE 25-75PSI

REVISIONS		DATE	APPROVED
ZONE	REV	DESCRIPTION	

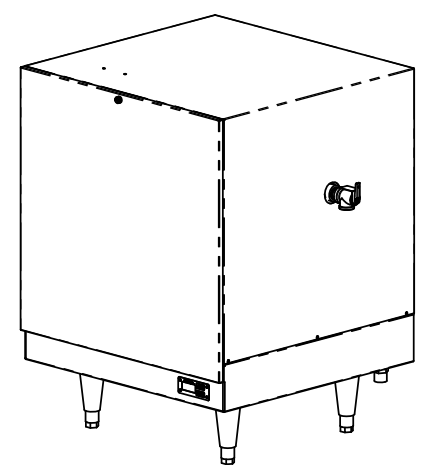
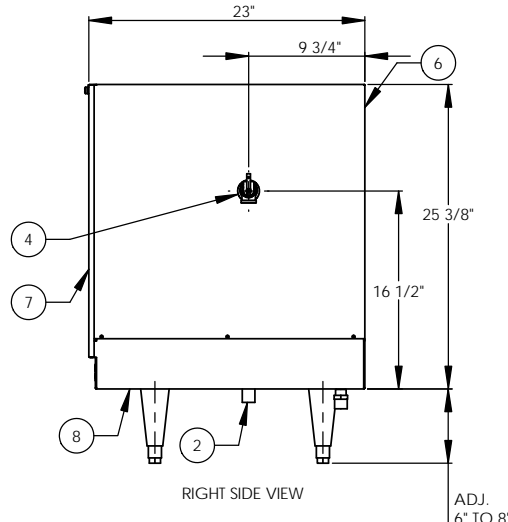
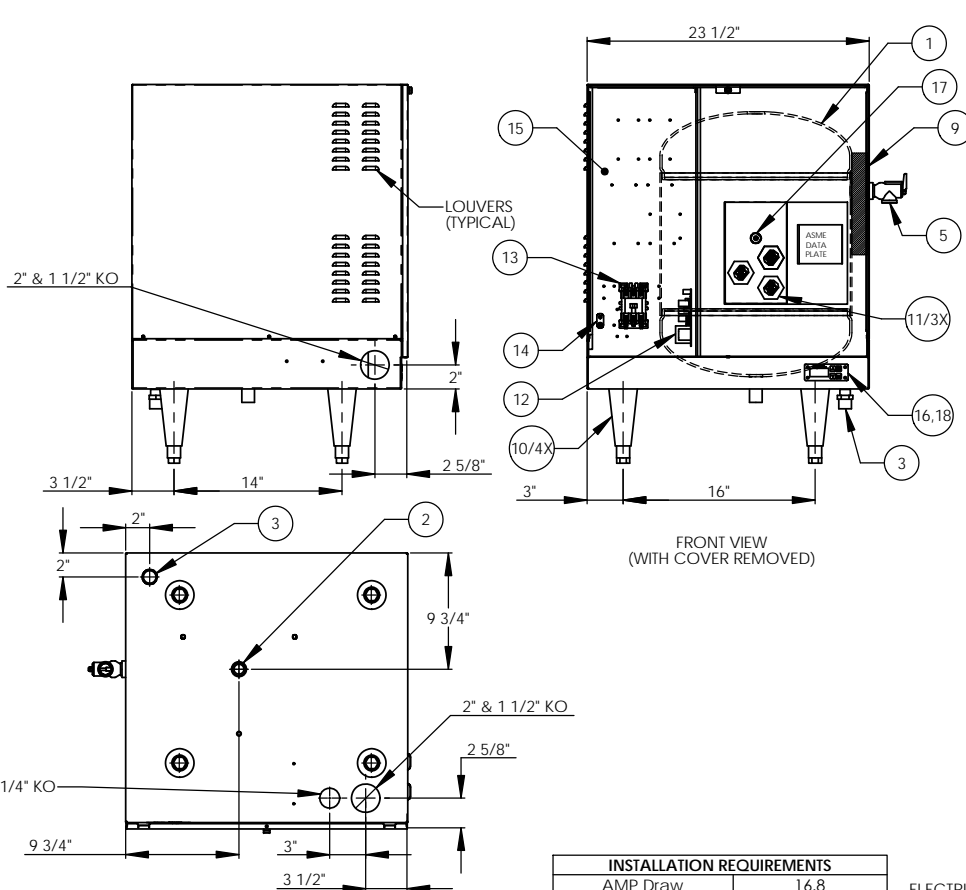

INSTALLATION REQUIREMENTS	
AMP Draw	16.8
Min. Breaker/Fuse Size	25 AMP
Cu Power Feed Wire	#10 AWG THHN
Min. Power Conduit	1/2"
Wiring Diagram	10 (NT)

ELECTRICAL NOTES:
 1. POWER FEED WIRE SIZING IS BASED ON 75°C Cu THHN WIRE WITH FEEDER BRANCH PROTECTION AT 125%.
 2. REFERENCE INSTALLATION, OPERATION, AND MAINTENANCE MANUAL FOR COMPLETE INSTALLATION INSTRUCTIONS.

- NOTES:**
- TANK IS DESIGNED, FABRICATED, AND STAMPED IAW ASME SECTION VIII CODE, LATEST ADDENDA.
 - TANK IS DESIGNED FOR 150PSI AND PRESSURE TESTED AT 225PSI.
 - PROBE ASSEMBLY (Pc. No. 17) PROVIDES TEMPERATURE CONTROL, HI-LIMIT, AND LOW WATER SENSING.
 - UNIT IS UL, CUL, AND UL EPH LISTED.
 - PIECE NOS. 5, 10, 20, & 21 ARE SHIPPED LOOSE.
 - CONTROL CIRCUIT WIRE TO BE #18 TEFZEL 750 (200°C), POWER CIRCUIT WIRE TO BE #12 TEFZEL 750 (200°C), ELEMENT JUMPER WIRE TO BE #12 TEFZEL 750 (200°C).
 - PHASE TO PHASE RESISTANCE: 16.5 OHMS
 - APPROXIMATE WEIGHT:
 DRY: 128 LBS.
 WET: 261 LBS.

DRAWN	DATE	NAME	Stratford, CT 06615
CHECKED	2/26/03	WENIII	(203) 378-2659
ENG APPR	2/26/03	PRD	Customer:
MFG APPR	2/26/03	CHD	Description: J MODEL BOOSTER HEATER J1671- 16 GALLON 7kW - 240V - 3Ø

PROPRIETARY AND CONFIDENTIAL
 THE INFORMATION CONTAINED IN THIS DRAWING IS THE SOLE PROPERTY OF THE ELECTRIC HEATER COMPANY. ANY REPRODUCTION IN PART OR AS A WHOLE WITHOUT THE WRITTEN PERMISSION OF THE ELECTRIC HEATER COMPANY IS PROHIBITED.

SIZE	DWG. NO	REV
C	J1671	
SCALE: 1:8	FSCM: 19857	SHEET 1 OF 1