

12kW - 240V - 3Ø - 28.9A

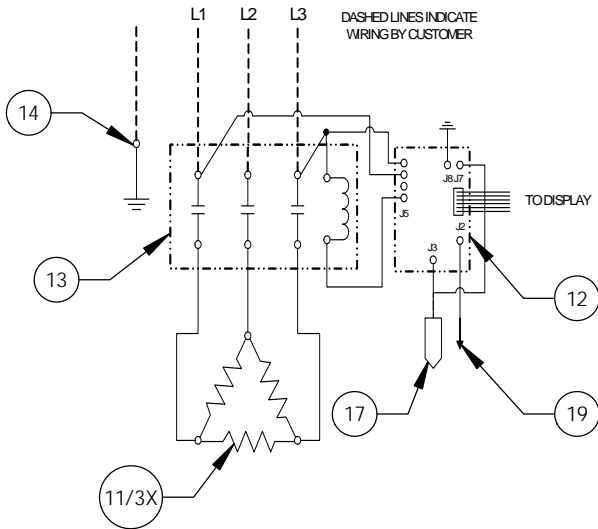

- NOTES:
- TANK IS DESIGNED, FABRICATED, AND STAMPED IAW ASME SECTION VIII CODE, LATEST ADDENDA.
 - TANK IS DESIGNED FOR 150PSI AND PRESSURE TESTED AT 225PSI.
 - PROBE ASSEMBLY (Pc. No. 17) PROVIDES TEMPERATURE CONTROL, HI-LIMIT, AND LOW WATER SENSING.
 - UNIT IS UL, CUL, AND UL EPH LISTED.
 - PIECE NOS. 5, 10, 20, AND 21 ARE SHIPPED LOOSE.
 - CONTROL CIRCUIT WIRE TO BE #18 TEFZEL 750 (200°C), POWER CIRCUIT WIRE TO BE #12 TEFZEL 750 (200°C). ELEMENT JUMPER WIRE TO BE #12 TEFZEL 750 (200°C).
 - PHASE TO PHASE RESISTANCE: 9.6 OHMS
 - APPROX. WEIGHT:
DRY: 85 LBS.
WET: 133 LBS.

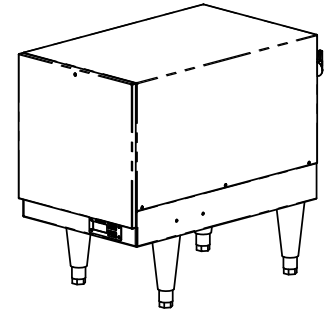
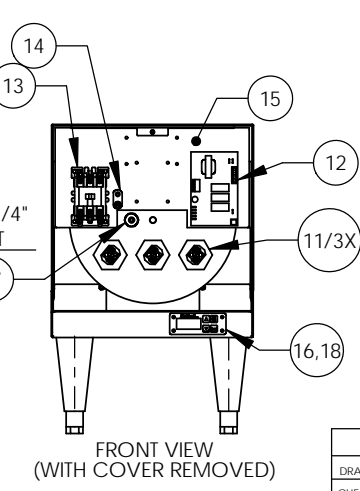
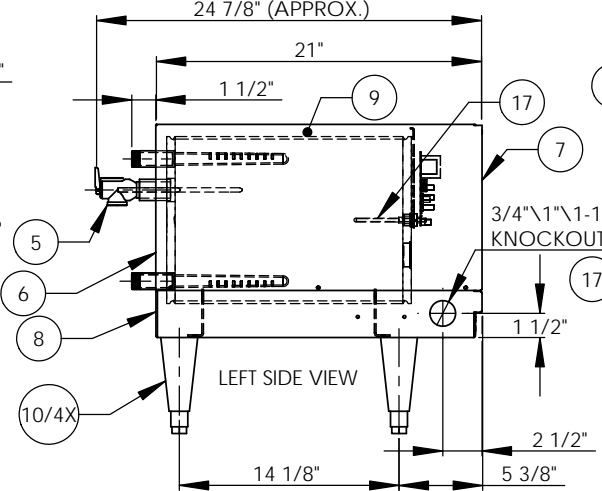
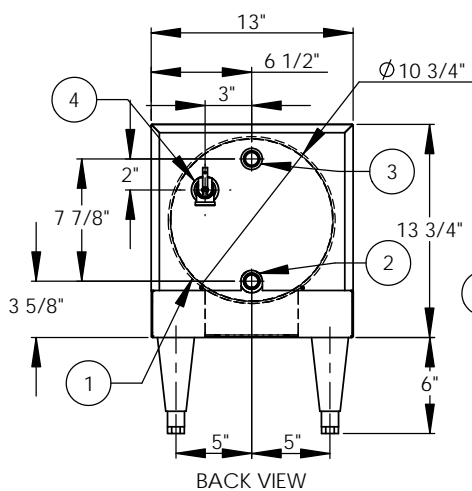
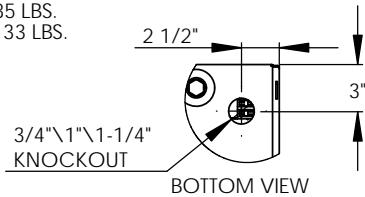

| ITEM NO. | QTY. | PART NO. | MATERIAL | DESCRIPTION |
|----------|------|--------------------|----------------------------|---|
| 1 | 1 | J6-3 TANK | 304L S/S | TANK ASSEMBLY |
| 2 | 1 | J6 INLET | BRASS | 3/4" MNPT INLET |
| 3 | 1 | J6 OUTLET | BRASS | 3/4" MNPT OUTLET |
| 4 | 1 | | BRASS | 3/4" FNPT FOR RELIEF VALVE |
| 5 | 1 | 100XL .75 150LB | BRONZE | RELIEF VALVE SET AT 150PSI, 210°F |
| 6 | 1 | J6-3 JACKET | 304 S/S | TOP COVER ASSEMBLY |
| 7 | 1 | J6-3 FRONT COVER | 304 S/S | FRONT COVER ASSEMBLY |
| 8 | 1 | J6-3 BASE | 304 S/S | BASE ASSEMBLY |
| 9 | 1 | | FOAM | INSULATION |
| 10 | 4 | 61649NOBN5T4 | PLASTIC | ADJUSTABLE LEGS |
| 11 | 3 | C1315-14 | BRASS PLUG & COPPER SHEATH | HEATING ELEMENT - 1-7/8" HEX 4000W @ 240V |
| 12 | 1 | T1000 | VARIOUS | CONTROL MODULE |
| 13 | 1 | C25DNF330B | VARIOUS | MAGNETIC CONTACTOR 40A (RESISTIVE) - 240V |
| 14 | 1 | KA8C | COPPER | GROUND LUG |
| 15 | 1 | J6-3 CONTROL PLATE | GALVANNEAL | ELECTRICAL MOUNTING PANEL |
| 16 | 1 | TD1000 | VARIOUS | DIGITAL DISPLAY MODULE |
| 17 | 1 | P65 | VARIOUS | PROBE ASSEMBLY |
| 18 | 1 | OVERLAY J MODEL | LEXAN | OVERLAY FOR DISPLAY MODULE |
| 19 | 1 | | VARIOUS | LEAK DETECTION SENSOR |
| 20 | 1 | TTD405 | VARIOUS | T&P GAUGE 30-240°F/0-200PSI |
| 21 | 1 | N45BU | BRONZE | PRESS. REDUCING VALVE 25-75PSI |

| ZONE | REV. | DESCRIPTION | DATE | APPROVED |
|------|------|-------------|------|----------|
| | | | | |

| DATE | NAME | REVISIONS |
|---------|--------|-----------|
| 2/5/03 | PRD | |
| 2/5/03 | WENIII | |
| 7/10/03 | PRD | |
| 8/29/03 | CHD | |

Hubbell™ Stratford, CT 06615
 (203) 378-2659
The Electric Heater Company
 Customer: _____
 Description: J MODEL BOOSTER HEATER
 J612T - 6 GALLON
 12kW - 240V - 3Ø

| SIZE | DWG. NO. | REV |
|----------|----------|-----|
| B | J612T | - |

SCALE: 1:8 FSCM: 19857 SHEET 1 OF 1

| INSTALLATION REQUIREMENTS | |
|---------------------------|-------------|
| AMP Draw | 28.9 |
| Min. Breaker/Fuse Size | 40 AMP |
| Cu Power Feed Wire | #8 AWG THHN |
| Min. Power Conduit | 1/2" |
| Wiring Diagram | 10 (NT) |

- ELECTRICAL NOTES:
- POWER FEED WIRE SIZING IS BASED ON 75°C Cu THHN WIRE WITH FEEDER BRANCH PROTECTION AT 125%.
 - REFERENCE INSTALLATION, OPERATION, AND MAINTENANCE MANUAL FOR COMPLETE INSTALLATION INSTRUCTIONS.

PROPRIETARY AND CONFIDENTIAL
 THE INFORMATION CONTAINED IN THIS DRAWING IS THE SOLE PROPERTY OF THE ELECTRIC HEATER COMPANY. ANY REPRODUCTION IN PART OR AS A WHOLE WITHOUT THE WRITTEN PERMISSION OF THE ELECTRIC HEATER COMPANY IS PROHIBITED.

DIMENSIONS ARE IN INCHES
 TOLERANCES:
 (UNLESS OTHERWISE SPECIFIED)
 FRACTIONAL ± 1/16"
 ANGULAR, MACH ± .05° BEND ± 1°
 TWO PLACE DECIMAL ± 0.01
 THREE PLACE DECIMAL ± 0.005