

ITEM NO.	QTY	PART NO.	MATERIAL	DESCRIPTION
1	1	J6-6 TANK	304L S/S	TANK ASSEMBLY
2	1	J6 INLET	BRASS	3/4" MNPT INLET
3	1	J6 OUTLET	BRASS	3/4" MNPT OUTLET
4	1		BRASS	3/4" FNPT FOR RELIEF VALVE
5	1	100XL .75 150LB	BRONZE	RELIEF VALVE SET AT 150PSI, 210°F
6	1	J6-6 JACKET	304 S/S	TOP COVER ASSEMBLY
7	1	J6-6 FRONT COVER	304 S/S	FRONT COVER ASSEMBLY
8	1	J6-6 BASE	304 S/S	BASE ASSEMBLY
9	1		FOAM	INSULATION
10	4	61649NOBN5T4	PLASTIC	ADJUSTABLE LEGS
11	6	C1315-13	BRASS PLUG & COPPER SHEATH	HEATING ELEMENT - 1-7/8" HEX 3500W @ 240V/7317W @ 600V
12	1	T1000	VARIOUS	CONTROL MODULE
13	1	C25DNF340B	VARIOUS	MAGNETIC CONTACTOR 50A (RESISTIVE) - 240V
14	1	KA4C	COPPER	GROUND LUG
15	1	J6-6 CONTROL PLATE	GALVANNEAL	ELECTRICAL MOUNTING PANEL
16	1	TD1000	VARIOUS	DIGITAL DISPLAY MODULE
17	1	P65	VARIOUS	PROBE ASSEMBLY
18	1	OVERLAY J MODEL	LEXAN	OVERLAY FOR DISPLAY MODULE
19	1		VARIOUS	LEAK DETECTION SENSOR
20	1	ITD405	VARIOUS	T&P GAUGE 30-240°F/0-200PSI
21	1	N45BU	BRONZE	PRESS. REDUCING VALVE 25-75PSI
22	1	B050-3350-3	VARIOUS	TRANSFORMER 50VA 600V/195V

- NOTES:
- TANK IS DESIGNED, FABRICATED, AND STAMPED IAW ASME SECTION VIII CODE, LATEST ADDENDA.
  - TANK IS DESIGNED FOR 150PSI AND PRESSURE TESTED AT 225PSI.
  - PROBE ASSEMBLY (Pc. No. 17) PROVIDES TEMPERATURE CONTROL, HI-LIMIT, AND LOW WATER SENSING.
  - UNIT IS UL, CUL, AND UL EPH LISTED.
  - PIECE NOS. 5, 10, 20, AND 21 ARE SHIPPED LOOSE.
  - CONTROL CIRCUIT WIRE TO BE #18 TEFZEL 750 (200°C), POWER CIRCUIT WIRE TO BE #10 TEFZEL 750 (200°C). ELEMENT JUMPER WIRE TO BE #12 TEFZEL 750 (200°C).
  - PHASE TO PHASE RESISTANCE: 16.4 OHMS
  - APPROX. WEIGHT:  
DRY: 98 LBS.  
WET: 146 LBS.
  - DERATE TO 40.32kW FOR 575V.

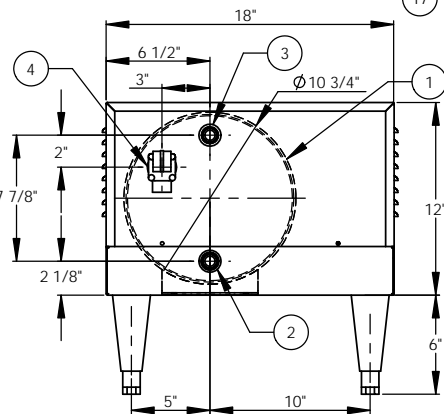

BACK VIEW

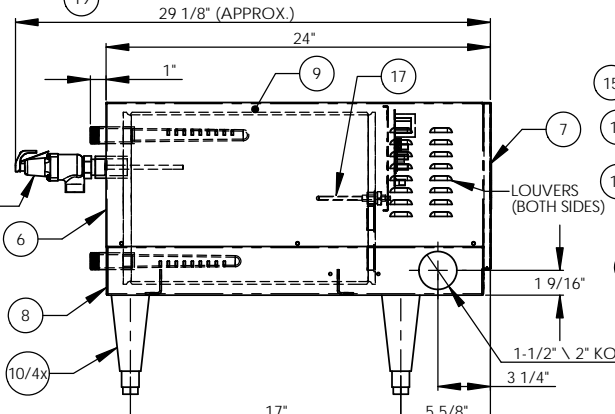

LEFT SIDE VIEW

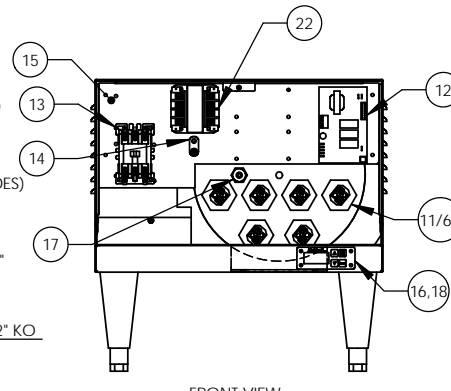

FRONT VIEW  
(WITH COVER REMOVED)

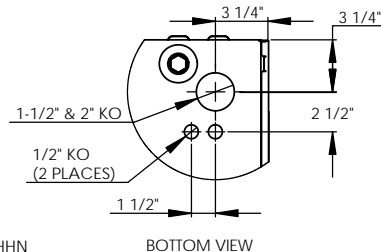
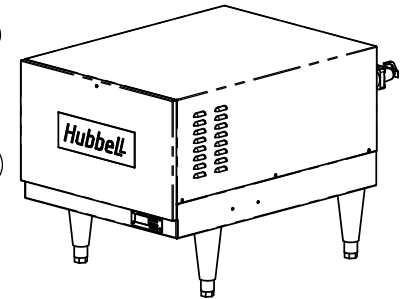

BOTTOM VIEW

INSTALLATION REQUIREMENTS	
AMP Draw	43.3
Min. Breaker/Fuse Size	55 AMP
Cu Power Feed Wire	#6 AWG THHN
Min. Power Conduit	3/4"
Wiring Diagram	15

- ELECTRICAL NOTES:
- POWER FEED WIRE SIZING IS BASED ON 75°C Cu THHN WIRE WITH FEEDER BRANCH PROTECTION AT 125%.
  - REFERENCE INSTALLATION, OPERATION, AND MAINTENANCE MANUAL FOR COMPLETE INSTALLATION INSTRUCTIONS.

DATE	NAME	REVISIONS	DESCRIPTION	DATE	APPROVED
2/21/05	SCL				
2/21/05	WENIII				
2/21/05	PRD				
2/21/05	CHD				

**Hubbell** Stratford, CT 06615  
 (203) 378-2659  
**The Electric Heater Company**  
 Customer: J Model Booster Heater  
 Description: J64516 - 6 GALLON  
 45kW - 600V - 3Ø

SCALE: 1:6	FSCM: 19857	SHEET 1 OF 1
------------	-------------	--------------

PROPRIETARY AND CONFIDENTIAL  
 THE INFORMATION CONTAINED IN THIS DRAWING IS THE SOLE PROPERTY OF THE ELECTRIC HEATER COMPANY. ANY REPRODUCTION IN PART OR AS A WHOLE WITHOUT THE WRITTEN PERMISSION OF THE ELECTRIC HEATER COMPANY IS PROHIBITED.

DIMENSIONS ARE IN INCHES  
 TOLERANCES:  
 (UNLESS OTHERWISE SPECIFIED)  
 FRACTIONAL: ±.005  
 ANGULAR: MATCH ±.1°  
 BEND: ±1°  
 TWO PLACE DECIMAL: ±0.01  
 THREE PLACE DECIMAL: ±0.005

SIZE	DWG. NO.	REV.
C	J64516	-