

8 7 6 5 4 3 2 1

4kW - 240V - 1Ø - 16.7A

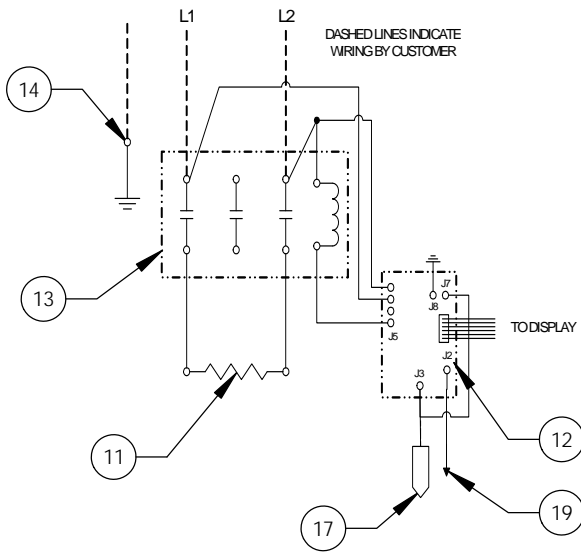

- NOTES:
- TANK IS DESIGNED, FABRICATED, AND STAMPED IAW ASME SECTION VIII CODE, LATEST ADDENDA.
  - TANK IS DESIGNED FOR 150PSI AND PRESSURE TESTED AT 225PSI.
  - PROBE ASSEMBLY (Pc. No. 17) PROVIDES TEMPERATURE CONTROL, HI-LIMIT, AND LOW WATER SENSING.
  - UNIT IS UL, CUL, AND UL EPH LISTED.
  - PIECE NOS. 5, 10, 20, AND 21 ARE SHIPPED LOOSE.
  - CONTROL CIRCUIT WIRE TO BE #18 TEFZEL 750 (200°C), POWER CIRCUIT WIRE TO BE #12 TEFZEL 750 (200°C). ELEMENT JUMPER WIRE TO BE #12 TEFZEL 750 (200°C).
  - PHASE TO PHASE RESISTANCE: 14.4 OHMS
  - APPROX. WEIGHT:  
DRY: 85 LBS.  
WET: 133 LBS.

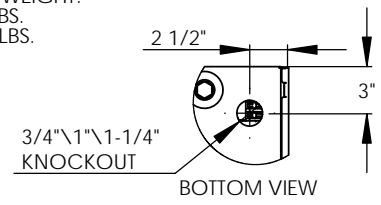

ITEM NO.	QTY	PART NO.	MATERIAL	DESCRIPTION
1	1	J6-3 TANK	304L S/S	TANK ASSEMBLY
2	1	J6 INLET	BRASS	3/4" MNPT INLET
3	1	J6 OUTLET	BRASS	3/4" MNPT OUTLET
4	1		BRASS	3/4" FNPT FOR RELIEF VALVE
5	1	100XL .75 150LB	BRONZE	RELIEF VALVE SET AT 150PSI, 210°F
6	1	J6-3 JACKET	304 S/S	TOP COVER ASSEMBLY
7	1	J6-3 FRONT COVER	304 S/S	FRONT COVER ASSEMBLY
8	1	J6-3 BASE	304 S/S	BASE ASSEMBLY
9	1		FOAM	INSULATION
10	4	61649NOBN5T4	PLASTIC	ADJUSTABLE LEGS
11	1	C1315-14	BRASS PLUG & COPPER SHEATH	HEATING ELEMENT - 1-7/8" HEX 4000W @ 240V
12	1	T1000	VARIOUS	CONTROL MODULE
13	1	C25DNF315B	VARIOUS	MAGNETIC CONTACTOR 20A (RESISTIVE) - 240V
14	1	K8C	COPPER	GROUND LUG
15	1	J6-3 CONTROL PLATE	GALVANNEAL	ELECTRICAL MOUNTING PANEL
16	1	TD1000	VARIOUS	DIGITAL DISPLAY MODULE
17	1	P65	VARIOUS	PROBE ASSEMBLY
18	1	OVERLAY J MODEL	LEXAN	OVERLAY FOR DISPLAY MODULE
19	1		VARIOUS	LEAK DETECTION SENSOR
20	1	TTD405	VARIOUS	T&P GAUGE 30-240°F/0-200PSI
21	1	N45BU	BRONZE	PRESS. REDUCING VALVE 25-75PSI

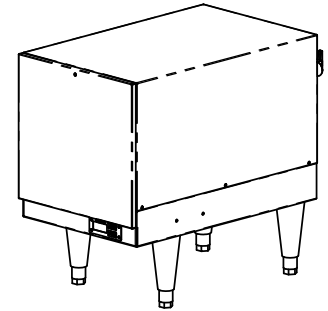
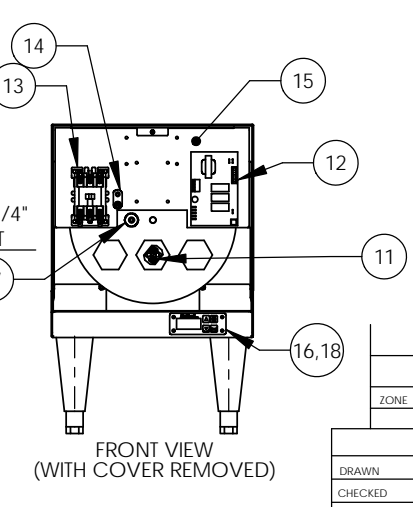
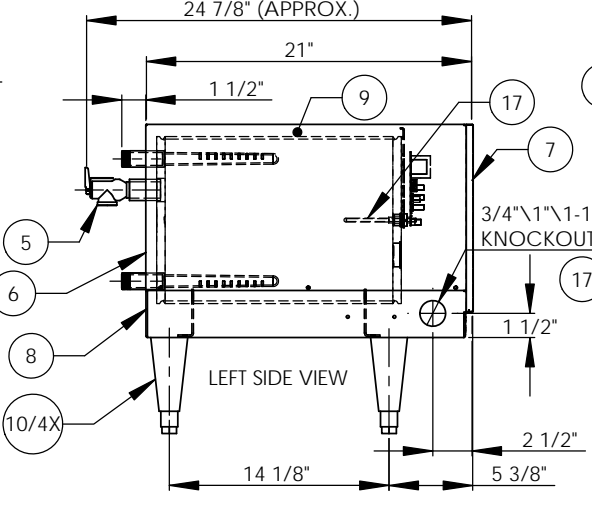
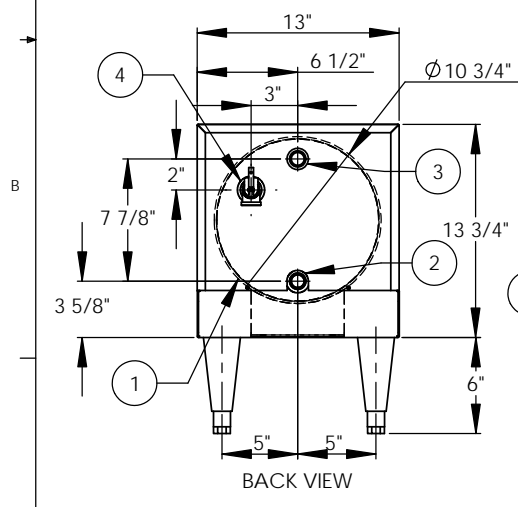

INSTALLATION REQUIREMENTS	
AMP Draw	16.7
Min. Breaker/Fuse Size	25 AMP
Cu Power Feed Wire	#12 AWG THHN
Min. Power Conduit	1/2"
Wiring Diagram	1(NT)

- ELECTRICAL NOTES:
- POWER FEED WIRE SIZING IS BASED ON 75 °C Cu THHN WIRE WITH FEEDER BRANCH PROTECTION AT 125%.
  - REFERENCE INSTALLATION, OPERATION, AND MAINTENANCE MANUAL FOR COMPLETE INSTALLATION INSTRUCTIONS.

**PROPRIETARY AND CONFIDENTIAL**  
THE INFORMATION CONTAINED IN THIS DRAWING IS THE SOLE PROPERTY OF THE ELECTRIC HEATER COMPANY. ANY REPRODUCTION IN PART OR AS A WHOLE WITHOUT THE WRITTEN PERMISSION OF THE ELECTRIC HEATER COMPANY IS PROHIBITED.

DIMENSIONS ARE IN INCHES TOLERANCES: (UNLESS OTHERWISE SPECIFIED)  
FRACTIONAL ±1/16  
ANGULAR MACH ±1/2° BEND ±1°  
TWO PLACE DECIMAL ±0.01  
THREE PLACE DECIMAL ±0.005

ZONE	REV.	DESCRIPTION	DATE	APPROVED

DATE	NAME	Stratford, CT 06615 (203) 378-2659 <b>The Electric Heater Company</b>
DRAWN 2/5/03	PRD	
CHECKED 2/5/03	WENIII	
ENG APPR. 7/10/03	PRD	
MFG APPR. 8/29/03	CHD	Customer:
Description: J MODEL BOOSTER HEATER J64S - 6 GALLON 4kW - 240V - 1Ø		
SIZE <b>B</b>	DWG. NO. J64S	REV -
SCALE: 1:8	FSCM: 19857	SHEET 1 OF 1

8 7 6 5 4 3 2 1