

ITEM NO.	QTY	PART NO.	MATERIAL	DESCRIPTION
1	1	J6-6 TANK	BRONZE	TANK ASSEMBLY
2	1	J6 INLET	BRASS	3/4" MNPT INLET
3	1	J6 OUTLET	BRASS	3/4" MNPT OUTLET
4	1		BRASS	3/4" FNPT FOR RELIEF VALVE
5	1	100XL 75 150LB	BRONZE	RELIEF VALVE SET AT 150PSI, 210°F
6	1	J6-6 JACKET	304 S/S	TOP COVER ASSEMBLY
7	1	J6-6 FRONT COVER	304 S/S	FRONT COVER ASSEMBLY
8	1	J6-6 BASE	304 S/S	BASE ASSEMBLY
9	1		FOAM	INSULATION
10	4	61649NOBN514	PLASTIC	ADJUSTABLE LEGS
11	6	C1315-15	BRASS PLUG & COPPER SHEATH	HEATING ELEMENT - 1-7/8" HEX 4500W @ 240V/9407W @ 600V
12	1	T1000	VARIOUS	CONTROL MODULE
13	1	C25DNF350B	VARIOUS	MAGNETIC CONTACTOR 65A (RESISTIVE) - 240V
14	1	KA4C	COPPER	GROUND LUG
15	1	J6-6 CONTROL PLATE	GALVANNEAL	ELECTRICAL MOUNTING PANEL
16	1	TD1000	VARIOUS	DIGITAL DISPLAY MODULE
17	1	P65	VARIOUS	PROBE ASSEMBLY
18	1	OVERLAY J MODEL	LEXAN	OVERLAY FOR DISPLAY MODULE
19	1		VARIOUS	LEAK DETECTION SENSOR
20	1	ITD405	VARIOUS	T&P GAUGE 30-240°F/0-200PSI
21	1	N45BU	BRONZE	PRESS. REDUCING VALVE 25-75PSI
22	1	B050-3350-3	VARIOUS	TRANSFORMER 50VA 600V/195V

REV. NO.		DESCRIPTION	DATE	APPROVED

- NOTES:
- TANK IS DESIGNED, FABRICATED, AND STAMPED IAW ASME SECTION VIII CODE, LATEST ADDENDA.
 - TANK IS DESIGNED FOR 150PSI AND PRESSURE TESTED AT 225PSI.
 - PROBE ASSEMBLY (Pc. No. 17) PROVIDES TEMPERATURE CONTROL, HI-LIMIT, AND LOW WATER SENSING.
 - UNIT IS UL, CUL, AND UL EPH LISTED.
 - PIECE NOS. 5, 10, 20, AND 21 ARE SHIPPED LOOSE.
 - CONTROL CIRCUIT WIRE TO BE #18 TEFZEL 750 (200°C), POWER CIRCUIT WIRE TO BE #8 TEFZEL 750 (200°C). ELEMENT JUMPER WIRE TO BE #10 TEFZEL 750 (200°C).
 - PHASE TO PHASE RESISTANCE: 12.8 OHMS
 - APPROX. WEIGHT:
DRY: 98 LBS.
WET: 146 LBS.
 - DERATE TO 51.84KW FOR 575V.

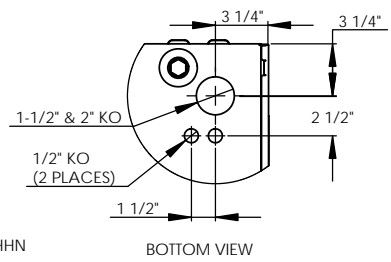
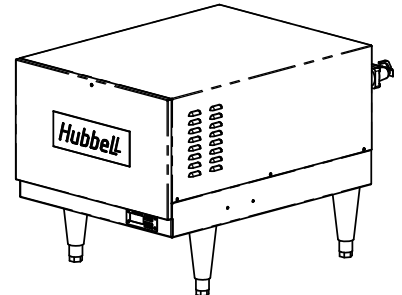
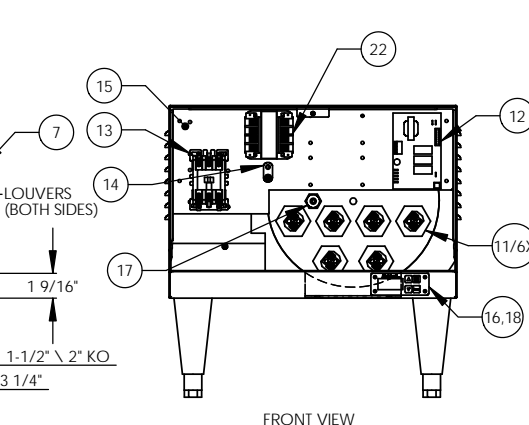
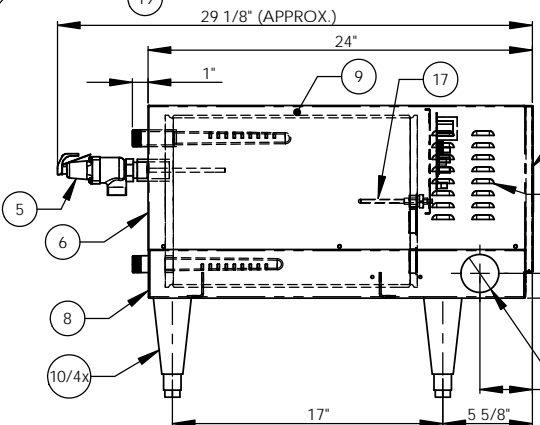
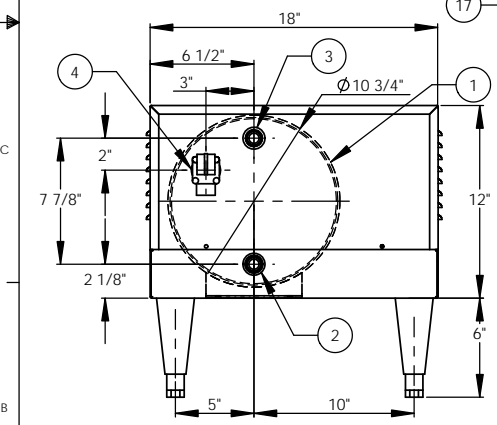

INSTALLATION REQUIREMENTS	
AMP Draw	52.0
Min. Breaker/Fuse Size	70 AMP
Cu Power Feed Wire	#4 AWG THHN
Min. Power Conduit	1"
Wiring Diagram	15

ELECTRICAL NOTES:
 1. POWER FEED WIRE SIZING IS BASED ON 75°C Cu THHN WIRE WITH FEEDER BRANCH PROTECTION AT 125%.
 2. REFERENCE INSTALLATION, OPERATION, AND MAINTENANCE MANUAL FOR COMPLETE INSTALLATION INSTRUCTIONS.

PROPRIETARY AND CONFIDENTIAL
 THE INFORMATION CONTAINED IN THIS DRAWING IS THE SOLE PROPERTY OF THE ELECTRIC HEATER COMPANY. ANY REPRODUCTION IN PART OR AS A WHOLE WITHOUT THE WRITTEN PERMISSION OF THE ELECTRIC HEATER COMPANY IS PROHIBITED.

DATE	NAME	DESCRIPTION
2/21/05	SCL	DRAWN
2/21/05	WENIII	CHECKED
2/21/05	PRD	ENG APPR
2/21/05	CHD	MFG APPR

Stratford, CT 06615
 (203) 378-2659
The Electric Heater Company
 Customer: J654T6
 Description: J MODEL BOOSTER HEATER
 J65416 - 6 GALLON
 56.4kW - 600V - 3Ø

SIZE	DWG. NO.	REV
C	J654T6	-

DIMENSIONS ARE IN INCHES
 TOLERANCES:
 (UNLESS OTHERWISE SPECIFIED)
 FRACTIONAL: 1/16"
 ANGULAR: MATCH ±1/2° BEND ±1°
 TWO PLACE DECIMAL: ±0.01
 THREE PLACE DECIMAL: ±0.005

SCALE: 1:6 FSCM: 19857 SHEET 1 OF 1