

9kW - 240V - 3Ø - 21.7A

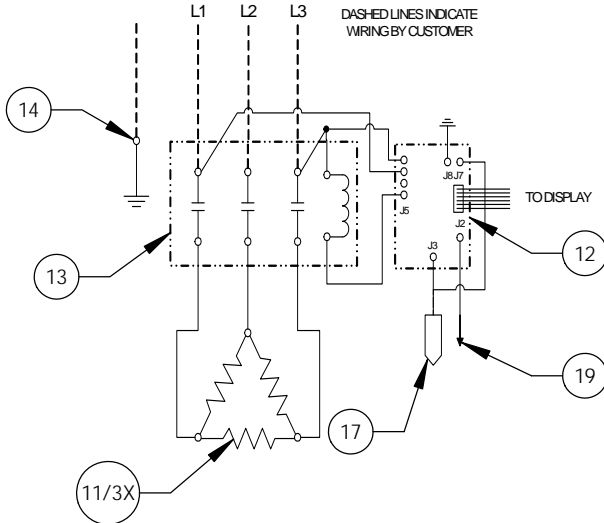

- NOTES:
1. TANK IS DESIGNED, FABRICATED, AND STAMPED IAW ASME SECTION VIII CODE, LATEST ADDENDA.
  2. TANK IS DESIGNED FOR 150PSI AND PRESSURE TESTED AT 225PSI.
  3. PROBE ASSEMBLY (Pc. No. 17) PROVIDES TEMPERATURE CONTROL, HI-LIMIT, AND LOW WATER SENSING.
  4. UNIT IS UL, CUL, AND UL EPH LISTED.
  5. PIECE NOS. 5, 10, 20, AND 21 ARE SHIPPED LOOSE.
  6. CONTROL CIRCUIT WIRE TO BE #18 TEFZEL 750 (200°C), POWER CIRCUIT AND JUMPER WIRE TO BE #10 TEFZEL 750 (200°C).
  7. JUMPER WIRE TO BE LONG ENOUGH TO FACILITATE FIELD CONVERSION.
  8. PHASE TO PHASE RESISTANCE: 12.8 OHMS
  9. APPROX. WEIGHT:  
DRY: 85 LBS.  
WET: 133 LBS.

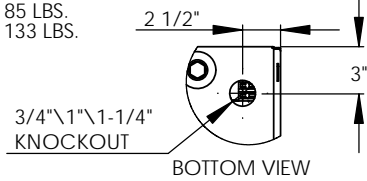

| ITEM NO. | QTY. | PART NO.           | MATERIAL                   | DESCRIPTION                               |
|----------|------|--------------------|----------------------------|---|
| 1        | 1    | J6-3 TANK          | 304L S/S                   | TANK ASSEMBLY                             |
| 2        | 1    | J6 INLET           | BRASS                      | 3/4" MNPT INLET                           |
| 3        | 1    | J6 OUTLET          | BRASS                      | 3/4" MNPT OUTLET                          |
| 4        | 1    |                    | BRASS                      | 3/4" FNPT FOR RELIEF VALVE                |
| 5        | 1    | 100XL .75 150LB    | BRONZE                     | RELIEF VALVE SET AT 150PSI, 210°F         |
| 6        | 1    | J6-3 JACKET        | 304 S/S                    | TOP COVER ASSEMBLY                        |
| 7        | 1    | J6-3 FRONT COVER   | 304 S/S                    | FRONT COVER ASSEMBLY                      |
| 8        | 1    | J6-3 BASE          | 304 S/S                    | BASE ASSEMBLY                             |
| 9        | 1    |                    | FOAM                       | INSULATION                                |
| 10       | 4    | 61649NOBN5T4       | PLASTIC                    | ADJUSTABLE LEGS                           |
| 11       | 3    | C1315-12           | BRASS PLUG & COPPER SHEATH | HEATING ELEMENT - 1-7/8" HEX 3000W @ 240V |
| 12       | 1    | T1000              | VARIOUS                    | CONTROL MODULE                            |
| 13       | 1    | C25DNF330B         | VARIOUS                    | MAGNETIC CONTACTOR 40A (RESISTIVE) - 240V |
| 14       | 1    | KA8C               | COPPER                     | GROUND LUG                                |
| 15       | 1    | J6-3 CONTROL PLATE | GALVANNEAL                 | ELECTRICAL MOUNTING PANEL                 |
| 16       | 1    | TD1000             | VARIOUS                    | DIGITAL DISPLAY MODULE                    |
| 17       | 1    | P65                | VARIOUS                    | PROBE ASSEMBLY                            |
| 18       | 1    | OVERLAY J MODEL    | LEXAN                      | OVERLAY FOR DISPLAY MODULE                |
| 19       | 1    |                    | VARIOUS                    | LEAK DETECTION SENSOR                     |
| 20       | 1    | TTD405             | VARIOUS                    | T&P GAUGE 30-240°F/0-200PSI               |
| 21       | 1    | N45BU              | BRONZE                     | PRESS. REDUCING VALVE 25-75PSI            |

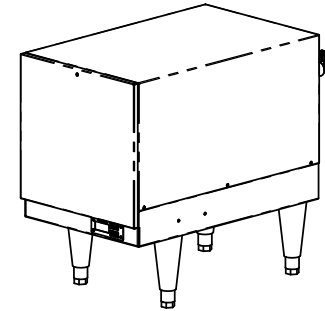
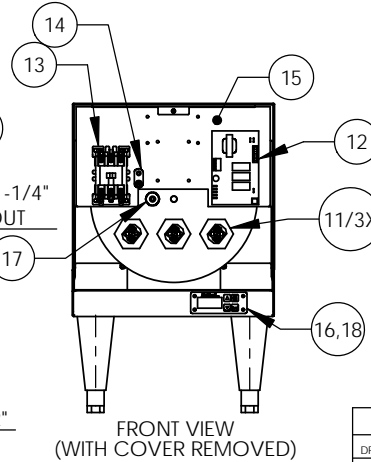
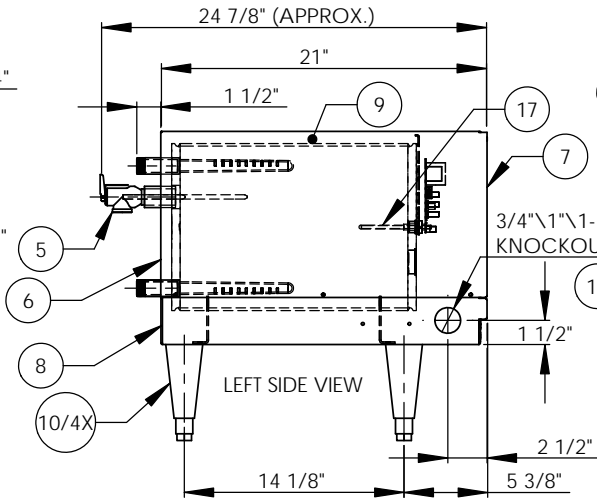
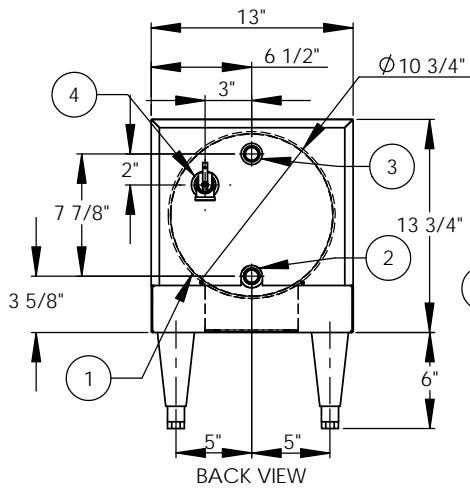

| INSTALLATION REQUIREMENTS |              |
|---------------------------|--------------|
| AMP Draw                  | 21.7         |
| Min. Breaker/Fuse Size    | 30 AMP       |
| Cu Power Feed Wire        | #10 AWG THHN |
| Min. Power Conduit        | 1/2"         |
| Wiring Diagram            | 10 (NT)      |

- ELECTRICAL NOTES:
1. POWER FEED WIRE SIZING IS BASED ON 75°C Cu THHN WIRE WITH FEEDER BRANCH PROTECTION AT 125%.
  2. REFERENCE INSTALLATION, OPERATION, AND MAINTENANCE MANUAL FOR COMPLETE INSTALLATION INSTRUCTIONS.

**PROPRIETARY AND CONFIDENTIAL**  
THE INFORMATION CONTAINED IN THIS DRAWING IS THE SOLE PROPERTY OF THE ELECTRIC HEATER COMPANY. ANY REPRODUCTION IN PART OR AS A WHOLE WITHOUT THE WRITTEN PERMISSION OF THE ELECTRIC HEATER COMPANY IS PROHIBITED.

DIMENSIONS ARE IN INCHES  
TOLERANCES:  
(UNLESS OTHERWISE SPECIFIED)  
FRACTIONAL ± 1/16  
ANGULAR: MACH ± 30' BEND ± 1"  
TWO PLACE DECIMAL ± 0.01  
THREE PLACE DECIMAL ± 0.005

| ZONE | REV. | DESCRIPTION | DATE | APPROVED |
|------|------|-------------|------|----------|
|      |      |             |      |          |

| DATE  | NAME        | Stratford, CT 06615<br>(203) 378-2659<br><b>The Electric Heater Company</b> |
|---|-------------|---|
| DRAWN 2/5/03  | PRD         |   |
| CHECKED 2/5/03  | WENIII      |   |
| ENG APPR. 7/10/03   | PRD         |   |
| MFG APPR. 8/29/03   | CHD         | Customer:   |
| Description: J MODEL BOOSTER HEATER<br>J69T - 6 GALLON<br>9kW - 240V - 3Ø |             |   |
| SCALE: 1:8  | FSCM: 19857 | SHEET 1 OF 1  |