

## Sanitizing Sink Heater

Providing a consistent and continuous supply of sanitizing rinse water for manual warewashing applications

- All stainless steel body and base
- Digital display for visual confirmation of set point temperature and fault conditions
- Equipped with a high temperature cut-off for built-in protection against higher than normal water temperature
- Low water cut off to prevent element burnout
- ETL (Sanitation NSF listed)
- Shipped ready to install with all gaskets and fittings
- Screw in type elements
- Separate sump and heating compartment drains allow for easy cleaning and sanitizing
- Standard 2" brass plated plumbing fittings for mounting under a sink
- Multiple voltage options available

### Applications

- 3 or 4 compartment sinks
- Pot and pan sinks
- Bar sinks



The Hubbell Expeditor JSK Sanitizing Sink Heater is designed for 3 or 4 compartment sinks, pot and pan sinks and bar sinks providing a consistent and continuous supply of sanitizing rinse water for manual warewashing applications. The JSK fits under the center of the sink so it doesn't take up any sink space and is easy to service and maintain.

Hubbell booster heaters are the right choice for your food service applications. Our boosters are designed, engineered, and manufactured for reliability and longevity coupled with unparalleled support and service.

**Get a booster heater from the booster heater experts.**



## Dimensions

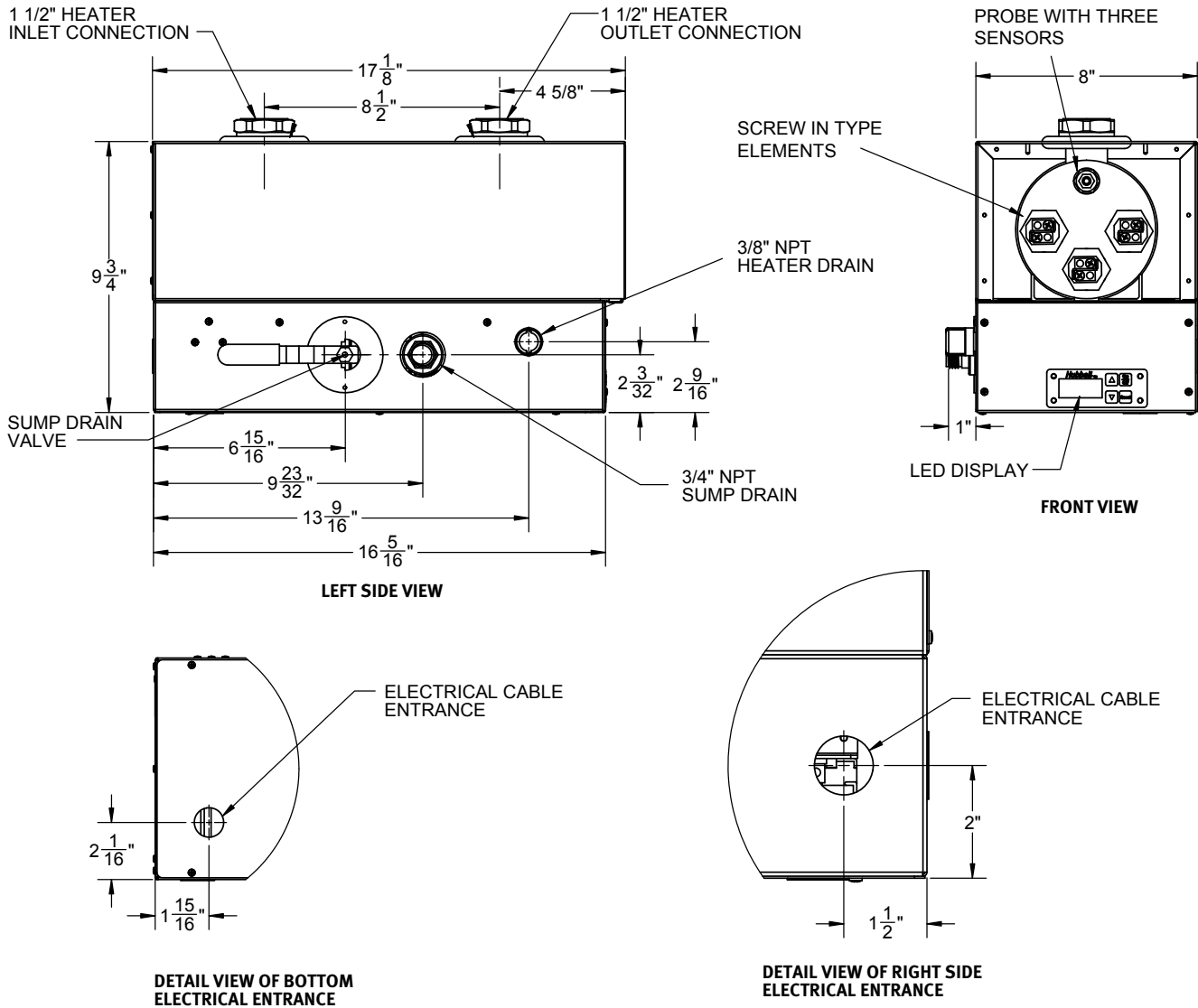

## JSK Selection Chart with Amperage

SINK AREA	KW	MODEL	VOLTAGE* 50/60 HZ	PHASE	AMPS	MIN. BREAKER SIZE	WIRING SIZING AWG
<b>15"</b> <b>(381 mm) Sq.</b> <b>or Less</b>	3	JSK-3RS	208	1	14.4	20	12
		JSK-3S	220 - 230 - 240		11.5 - 12.0 - 12.5	15 - 15 - 20	14 - 14 - 12
		JSK-3T4S	480		6.3	15	14
		JSK-3R	208	3	8.3		
		JSK-3T	240		7.2		
		JSK-3T4	480		3.6		
		JSK-3T6	600		3.0		
<b>16" - 18"</b> <b>(406 - 457 mm) Sq.</b>	4.5	JSK-4RS	208	1	21.7	30	8
		JSK-4S	220 - 230 - 240		17.2 - 18.0 - 18.8	25	10
		JSK-4T4S	480		9.4	15	14
		JSK-4R	208	3	12.5	20	12
		JSK-4T	240		10.8	15	14
		JSK-4T4	480		5.4		
		JSK-4T6	600		4.5		
<b>19" - 21"</b> <b>(483 - 533 mm) Sq.</b>	6	JSK-6RS	208	1	28.9		
		JSK-6S	220 - 230 - 240		22.9 - 24.0 - 25.0	30 - 30 - 35	
		JSK-6T4S	480		12.5	20	12
		JSK-6R	208	3	16.7	25	10
		JSK-6T	240		14.4	20	12
		JSK-6T4	480		7.2	15	12
		JSK-6T6	600		6.0		
<b>21" - 25"</b> <b>(533 - 635 mm) Sq.</b>	9	JSK-9RS	208	1	43.3	60	4
		JSK-9S	220 - 230 - 240		34.4 - 35.9 - 37.5	45 - 45 - 50	6 - 6 - 4
		JSK-9T4S	480		18.8	25	10
		JSK-9R	208	3	25.0	40	10
		JSK-9T	240		21.7	30	8
		JSK-9T4	480		10.8	15	14
		JSK-9T6	600		9.0		

\*Models are also available in 277, 380, 400, 415 and 440 volt. Please consult factory for exact model selection in these voltages.

**Warranty:** All Hubbell Model JSK Booster Heaters are backed by a full 1 year parts/labor warranty and additional 4 year tank warranty





## Complete Inventory Ready to Ship

Hubbell Expeditor booster heaters are ready to ship same day when an order is received by the factory by 12:00pm EST.

800.647.3165  
info@boosterheaters.com  
boosterheaters.com

45 Seymour Street, P.O. Box 288, Stratford, CT 06615



H1013-B-20241212