



# High Efficiency Compact Electric Tankless Booster Heater

98%+ efficient, easy to install  
and operate. Available up to 54 kW  
in single or three phase voltages

For use with conveyor and flight type dish  
machines, not intended for use with door  
style dish machines

Instantaneous design reduces stand-by heat  
loss and significantly lowers operating costs  
compared to traditional storage systems

Constructed with high-grade materials  
to ensure long operating life

- Digital display provides clear indication of set point temperature and fault conditions
- Factory packaged heater provides trouble-free installation and operation
- Engineered specifically for use in commercial kitchens
- Wide selection of sizes to meet the needs of all dish machine manufacturers

## Applications

Dish machine booster, hood washing,  
pot washers, point-of-use water heating,  
three compartment sinks.



# JTX

EXPEDITOR SERIES

## Tankless water heater for commercial kitchens

The Hubbell Expeditor JTX tankless electric water heater is highly reliable and easy to maintain. The JTX is compact, extremely efficient, takes up minimal space, and reduces operating costs.

Hubbell booster heaters are the right choice for your food service applications. Our boosters are designed, engineered, and manufactured for reliability and longevity coupled with unparalleled support and service.

**Get a booster heater from the booster heater experts.**



## Inside the Expeditor JTX

The Hubbell Expeditor JTX uses only the power needed to heat water on demand, while delivering an accurate and consistent water temperature. The controller continually processes the flow rate along with the

inlet and outlet temperature to determine the amount of energy needed to achieve the desired water temperature. Fast-acting TRIACS modulate the heating elements to the precise level needed to meet the demand.

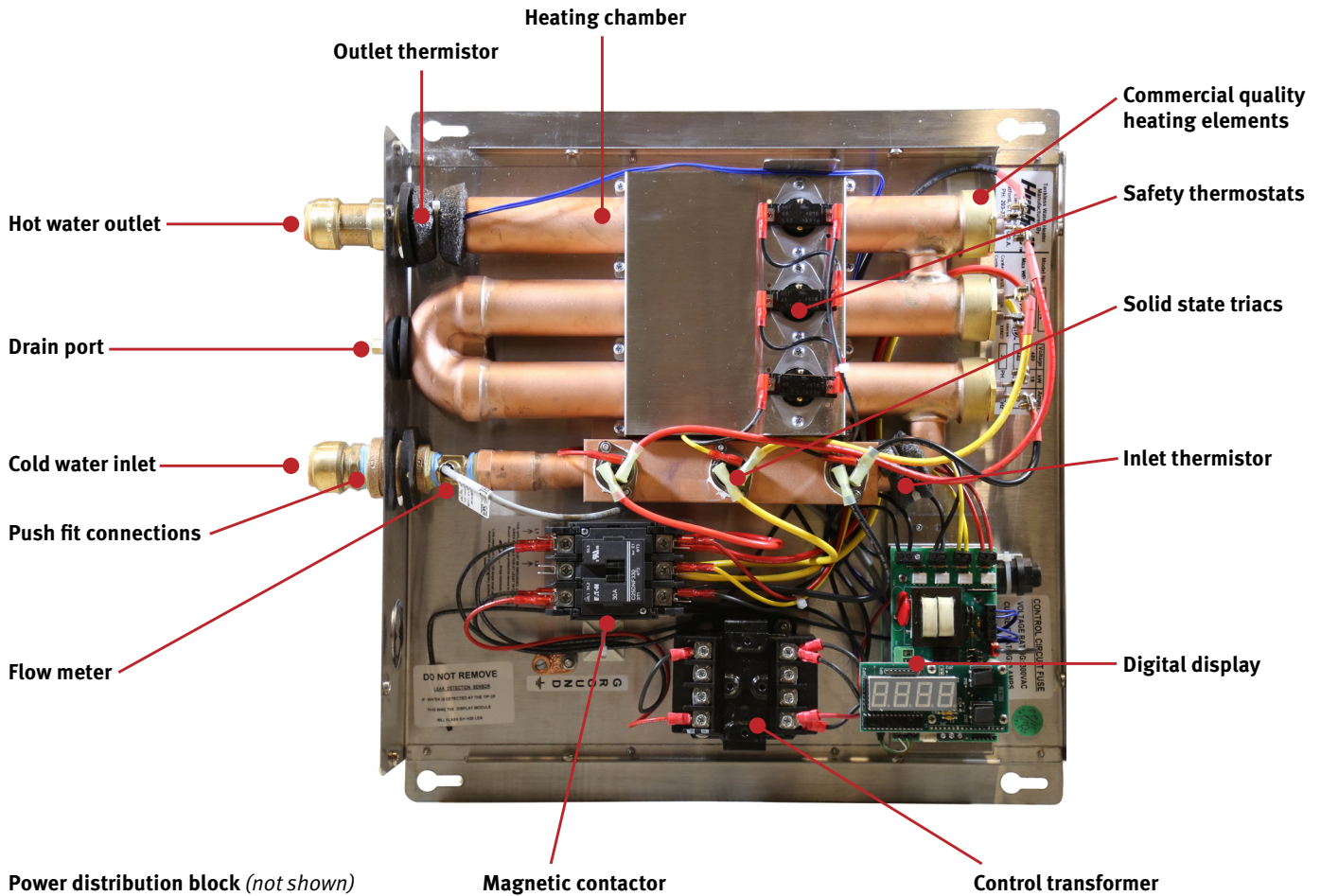

## Technical Features

### Temperature Controller

A sophisticated electronic temperature controller with LED digital display provides the user interface. The temperature controller processes all flow and temperature data and calculates the precise amount of power needed to meet demand.

Operator Control Capabilities	
Power Limiting	This feature allows the user to limit the kW rating of the unit by a specific percentage and effectively lower the total amp draw of the unit.
Diagnostics	Display inlet and outlet temperatures, flow rate and error codes to assist in troubleshooting.
Cost Calculator	Determine the exact cost of operating the heater. Input your cost per kW·Hr and the controller displays total kW·HRs consumed, total cost of operation, and total hot water usage (shown in gallons or liters).
Temperature Control	Set the digital display to the desired water temperature in °F or °C. Fully adjustable in 1° increments from 32–194°F (0–90°C). A user adjustable +/- 3° calibration feature provides additional control for superior accuracy.

### Full Heater Modulation

Each heating element is switched on/off using a fast acting solid state TRIAC with zero cross over firing control. This switching action provides full modulation of each heating element, ensuring that the precise amount of heat is added to meet demand. To improve operating efficiency and component longevity, each TRIAC is mounted to a heat sink located on the incoming supply piping so that heat generated by the TRIAC during the switching process is dissipated into the water.

### Proper Power Integrity

All Hubbell Infinity tankless water heaters, including all 3 phase models, are engineered to operate as a balanced load and operate at 0.999 Power Factor. All Hubbell 3 phase models are designed for 3 wire (3 live, 1 ground) and 4 wire power systems and draw equal current across all conductors to maintain the power integrity of the users electrical system. Hubbell does not recommend the use of heaters that operate as an unbalanced load. All load switching in Hubbell tankless models is performed as zero cross over, eliminating phase angle firing interference and associated EMI issues.

### Full Resource Staging

The Hubbell Infinity tankless control system ensures that usage is equalized across all heating circuits. To achieve this, once the controller has calculated the precise amount of kW required, all circuits are energized proportionally and independently energized and then time staggered between circuits. This full resource staging reduces EMI output, increases component longevity, and provides highly accurate and consistent hot water temperatures. For three phase models, all circuits are fully modulated and synchronized to operate as a balanced load.

### BACnet Module

The Hubbell BACnet interface unit implements BACnet MS/TP protocol. The device comes from the factory ready to be operated. The unit can be reconfigured easily with a USB cable and the BACnet Network Utility program located on the Hubbell website. The BACnet includes features such as set temperature, power limiting, power setting, temperature in and out, flow rate, flowmeter error and leak detections. Note that internet protocol is not supported.

**For use with conveyor and flight type dish machines, not intended for use with door style dish machines. If your conveyor or flight type machine has a "seeing eye" consult factory.**

## Heater Specifications

<b>Heating Chamber</b>	Copper and Bronze
<b>Capacities</b>	8–54 kW
<b>Orientation</b>	Wall Mounted
<b>Voltages</b>	208–600 Volt, 50/60 HZ
<b>Phases</b>	1Φ or 3Φ (balanced)
<b>Power Factor</b>	0.999
<b>Thermal Efficiency</b>	98% +
<b>Inlet / Outlet Size</b>	JTX: 3/4" Dielectric Union Copper Sweat JHX: 1" Dielectric Union Copper Sweat
<b>Min/Max Flow</b>	JTX: 0.2 GPM Min, 8.0 GPM Max JHX: 0.5 GPM Min, 40 GPM Max
<b>Max Inlet Temp.</b>	150°F
<b>Thermostat Range</b>	32–194°F / 0– 90°C
<b>Hi-Limit</b>	200°F (Fixed temperature)
<b>Design WP</b>	150 psi
<b>Design TP</b>	225 psi
<b>Elements</b>	Incoloy 800
<b>Standby Power</b>	< 3 Watts
<b>Heating Chamber Warranty</b>	5 Year
<b>Electrical Warranty</b>	1 Year
<b>Labor Warranty</b>	1 Year
<b>Enclosure</b>	Stainless Steel Brushed Finish
<b>Approvals</b>	ETL, ANSI/NSF 5

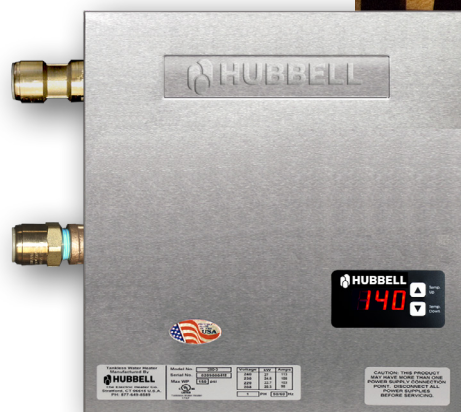

# kW and Amperage Selection Charts

## 3 Element

(Amperage shown in chart below indicates available models)

kW Rating	1 Phase Voltages		3 Phase Voltages			
	208	240	208	240	480	600
8					10	
11			31			
12		50	33		14	
14				34		
16	77		44	39		
18	87		50		22	
20	96		56			
21		88		51	25	20
24		100		58	29	23
27		113		65	33	26

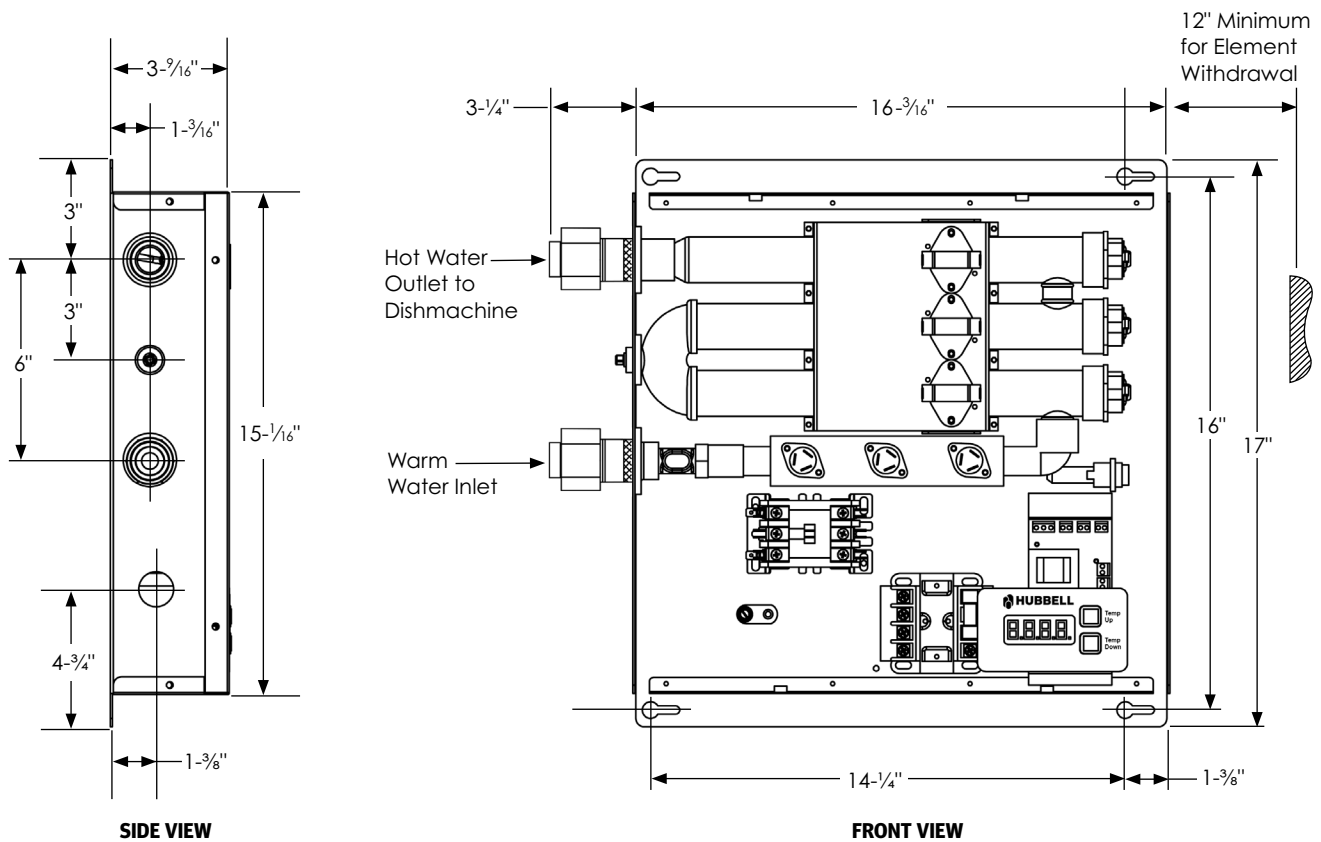

# kW and Amperage Selection Charts

## 6 Element

(Amperage shown in chart below indicates available models)

kW Rating	1 Phase Voltages		3 Phase Voltages			
	208	240	208	240	480	600
24	115		67			
31	149		86			
33		138		79		
35						34
36	173		100	87	43	
40	192		111			39
42		175		101	51	40
48	231	200	133	116	58	46
50						48
54		225		130	65	52

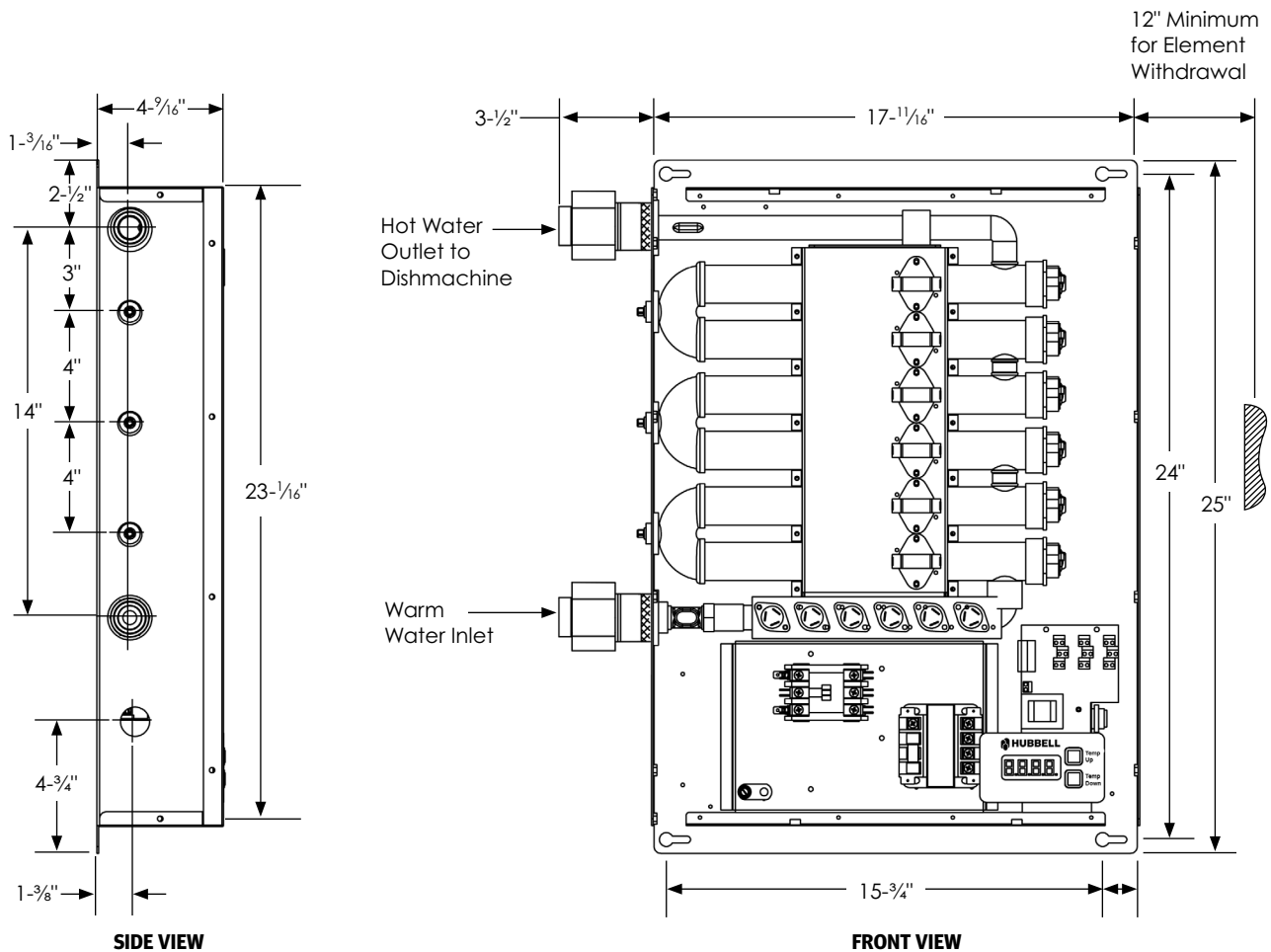

# Heating Capacity

kW Rating	Heating Capability in GPM at F° Temperature Rise (°FΔT)									
	20°F ΔT	30°F ΔT	40°F ΔT	60°F ΔT	70°F ΔT	80°F ΔT	100°F ΔT	110°F ΔT	120°F ΔT	140°F ΔT
8	2.73	1.82	1.36	0.91	0.78	0.68	0.55	0.50	0.45	0.39
11	3.75	2.50	1.88	1.25	1.07	0.94	0.75	0.68	0.63	0.54
12	4.09	2.73	2.05	1.36	1.17	1.02	0.82	0.74	0.68	0.58
14	4.78	3.18	2.39	1.59	1.36	1.19	0.96	0.87	0.80	0.68
16	5.46	3.64	2.73	1.82	1.56	1.36	1.09	0.99	0.91	0.78
18	6.14	4.09	3.07	2.05	1.75	1.54	1.23	1.12	1.02	0.88
20	6.82	4.55	3.41	2.27	1.95	1.71	1.36	1.24	1.14	0.97
21	7.17	4.78	3.58	2.39	2.05	1.79	1.43	1.30	1.19	1.02
24	8.19	5.46	4.09	2.73	2.34	2.05	1.64	1.49	1.36	1.17
27	9.21	6.14	4.61	3.07	2.63	2.30	1.84	1.67	1.54	1.32
31	10.58	7.05	5.29	3.53	3.02	2.63	2.12	1.92	1.76	1.51
33	11.26	7.51	5.63	3.75	3.22	2.81	2.25	2.05	1.88	1.61
36	12.28	8.19	6.14	4.09	3.51	3.07	2.46	2.23	2.05	1.75
40	13.65	9.10	6.82	4.55	3.90	3.41	2.73	2.48	2.27	1.95
42	14.33	9.55	7.17	4.78	4.09	3.58	2.87	2.61	2.39	2.05
48	16.38	10.92	8.19	5.46	4.68	4.09	3.28	2.98	2.73	2.34
54	18.42	12.28	9.21	6.14	5.26	4.61	3.68	3.35	3.07	2.63

**Notes**

Alternate voltages including 277, 380, 415, 440 and 575 volt available. Please consult factory for exact kW availability in these voltages.

  Specify Expeditor JHX due to high flow rate

## Variables to Solve For

**Step 1:** Solve for the unknown using the formulas below.

**kW Requirement:**

$$\text{_____ GPM} \times \text{_____ } ^\circ\text{F}\Delta\text{T} \times 0.1465 = \text{_____ kW}$$

**Temperature Rise:**

$$\text{_____ kW} \times 6.824 \div \text{_____ GPM} = \text{_____ } ^\circ\text{F}\Delta\text{T}$$

**Flow Rate:**

$$\text{kW} \times 6.824 \div \text{_____ } ^\circ\text{F}\Delta\text{T} = \text{_____ GPH}$$

**Step 2:** Choose the Tankless model with the kW rating which meets the peak demand (GPM) and required temperature rise (°FΔT) for your application.

**Step 3:** Choose the voltage and phase power supply available. Note the total amperage draw of the unit and verify availability.

## Voltage De-Rating Factors

Rated Voltage	Applied Voltage	De-Rating Factor
600 V	575 V	92%
600 V	550 V	84%
480 V	460 V	92%
480 V	440 V	84%
240 V	230 V	92%
240 V	220 V	84%
240 V	208 V	75%

When the actual supply voltage (applied voltage) is different than the design voltage (rated voltage) the resulting kW output will be affected. Please see the chart for typical voltage de-rating factors, or use the following formula.

$$\frac{\text{Applied Voltage}^2}{\text{Rated Voltage}^2} \times \text{Rated kW} = \text{kW output at applied voltage}$$

## Expeditor TX/HX Model Number Designation

MODEL	See pages 5–6 for available kW and heating element combinations.			OPTIONAL EQUIPMENT
	KW RATING	NUMBER OF HEATING ELEMENTS	VOLTAGE / PHASE	
<b>JTX</b> = 0.2 GPM Min 8.0 GPM Max	008 – 054	2	<b>Single Phase</b>	Write/type optional equipment code in the gray box below in alphabetical order. For multiple options separate codes with a dash (-).
<b>JHX</b> = High Flow 0.5 GPM Min 40 GPM Max		3	<b>RS</b> = 208/1	
		6	<b>S</b> = 240/1	
		<b>Balanced 3Φ</b>		
		<b>R</b> = 208/3		
		<b>T</b> = 240/3		
		<b>T3</b> = 380/3		
		<b>T7</b> = 415/3		
		<b>T5</b> = 440/3		
		<b>T4</b> = 480/3		
		<b>T6</b> = 600/3		

### Example: JTX024-3T4-C35

A Hubbell Expeditor JTX tankless electric water heater rated at 24 kW with 3 heating elements and powered with 480 volt, three phase, 60 Hz. With optional BACnet communication module with T1000 digital controller.

## Optional Equipment

**Note:** Optional equipment must be called out in the written specifications, use the codes below.

### Controller

- C35** BACnet communication module with T1000 digital controller
- C51** Remote Control Display allows the heater to be installed in a remote location. The 3" x 5" NEMA 4 display enclosure can be located up to 25' from the heater

### General

- G16** NEMA 4 or NEMA 4X rating

**Please note:** Optional equipment may impact overall dimensions and weight. Please request submittal drawing from factory.

## Available Accessories

**Tankless Valve Kit:** Inlet and outlet valve assembly simplifies installation. Includes unions, shut offs, check valve, drain ports and pressure relief valve. For ¾" order part number LFTWH-UT-HC  
For 1" order part number TANKLESS VALVE KIT 1

**Thermostatic Mixing Valve:** ASSE 1070 code compliant Thermostatic mixing valve to increase the amount of hot water available. Valve is ½" (-UT) size and adjustable from 80–120°F. Typically used when supplying hot water to multiple lavatories from a single water heater. Order part number LFMMVM1-UT

Fill out form below to order accessories.

Accessories Name _____	Part # _____
Accessories Name _____	Part # _____
Accessories Name _____	Part # _____